

# Acoustic communication in two spider species of the genus *Steatoda* (Araneae, Theridiidae)

**Journal Article****Author(s):**

Lee, R.C.P.; Nyffeler, Martin; Krelina, E.; Pennycook, B.W.

**Publication date:**

1986

**Permanent link:**

<https://doi.org/10.3929/ethz-a-005779308>

**Rights / license:**

In Copyright - Non-Commercial Use Permitted

**Originally published in:**

Mitteilungen der Schweizerischen Entomologischen Gesellschaft 59

Acoustic communication in two spider species of the genus  
*Steatoda* (Araneae, Theridiidae)R. C. P. LEE<sup>1, 5</sup>, M. NYFFELER<sup>2</sup>, E. KRELINA<sup>3</sup> & B. W. PENNYCOOK<sup>4</sup><sup>1</sup> Department of Biology, Queen's University, Kingston, Ontario, Canada<sup>2</sup> Department of Entomology, ETH-Zentrum, CH-8092 Zurich<sup>3</sup> Biosystematics Research Institute, Agriculture Canada, Ottawa, Canada<sup>4</sup> Department of Music, Queen's University, Kingston, Ontario, Canada

*Steatoda bipunctata* and *S. borealis* are two closely related species of spiders, which were entirely allopatric until approximately one hundred years ago, when *S. bipunctata* was introduced into the range of *S. borealis*, where it has since spread. Reproductive isolation between the two species apparently results from mechanical incompatibility of their copulatory organs. In this report, the stridulatory organs of the males are described, and the sounds produced by males during sexual and agonistic behaviour are analysed. The interspecific differences in the sounds are small compared with the range of variation within the species. The stridulatory organs are extremely similar in the two species. There is no evidence that differences in male sounds could be used as a cue for species recognition. This is in contrast with species which have co-existed for longer periods, and which apparently use species-specific sounds as recognition mechanisms.

Sound production in spiders has been known for a long time (e.g. DAVIS, 1904; LAHEE, 1904; PRELL, 1916; ALLARD, 1936), but so far it has received relatively little study. Several different mechanisms of sound production have been described (e.g. ROVNER, 1980; EDWARDS, 1981; UETZ & STRATTON, 1982). Questions about the functional and evolutionary significance of these sounds may be asked, notably about their roles in sex and species recognition. Previously, experimental work in this field has largely been conducted on lycosid spiders (ROVNER, 1967, 1975; HARRISON, 1969; BUCKLE, 1972; STRATTON & UETZ, 1981, 1983).

In this paper, sounds produced by theridiid spiders are described. *Steatoda bipunctata* (L.) and *S. borealis* (HENTZ) are two quite closely related species. The external genital organs are very distinct, but otherwise there is no morphological characteristic by which they may be distinguished. They are brown to almost black coloured, with a shiny abdomen and a body length of up to 7 mm. *S. bipunctata* is a native of Europe and parts of Asia (WIEHLE, 1937); *S. borealis* is native to North America (LEVI, 1957; GERTSCH, 1979). The two species were thus allopatric until the introduction of *S. bipunctata* to North America, probably in the late nineteenth century. The present range of *S. bipunctata* covers parts of south-eastern Canada and north-eastern U.S.A. It has apparently displaced *S. borealis* in some localities on the east coast and along the St. Lawrence Seaway, but in other localities in the same region the two species currently co-exist in mixed populations (NYFFELER *et al.*, 1986). In 1983-1984 the ecology and behaviour of the two species were studied at the Biosystematics Research Institute, Ottawa, with the

<sup>5</sup> Present address: c/o Beech Court, Okehampton, Devon EX20 1LE, England

aim of investigating the causes underlying the apparent displacement of *S. borealis* by *S. bipunctata* (NYFFELER *et al.*, 1986). The two species were found to be ecologically highly similar, both being found in the same types of habitat (buildings, tree trunks, rock crevices, etc.), sometimes together. In such mixed populations, males of either species occasionally enter the webs of heterospecific females during the courtship season. In the laboratory, such males will court heterospecific females (NYFFELER *et al.*, 1986).

The courtship of *S. bipunctata* has previously been described (GWINNER-HANKE, 1970). The male enters the female's web, and initiates a display featuring stridulation. This is a scratching sound produced by friction between structures on the posterior cephalothorax and anterior abdomen. These sounds were estimated to have fundamental frequencies between 800 and 1000 Hz. The sound of stridulation elicits female receptivity, even if the male is outside the web. Males cannot court successfully if the stridulatory organ is eliminated by a covering of lacquer. Stridulation also occurs in male-male agonistic interactions.

The aim of the study presented here was to describe the stridulatory sounds of *S. bipunctata* and *S. borealis* in more detail than hitherto and to see if there were any consistent differences between the stridulations of the two species, which could play a role in species recognition.

## METHOD

### *Spider Subject Material*

In spring 1984, mature males and females of both species were collected in barns in the farming district around Ottawa. These were kept in the laboratory in individual plastic jars with ventilating holes in the lids, and provided with dipteran prey and water drops.

### *The Scanning Electron Micrographs*

These were taken with a Cambridge scanning electron microscope, with a 20 kV accelerating voltage. The specimens, which had been preserved in 75% alcohol, were dehydrated with 100% alcohol, mounted on stubs with Sellotape glue, and left for 48 hours in a dessicator before coating with gold for observation. Four specimens of each species were prepared for SEM observation. The cephalothorax and abdomen were separated, so that each part of the stridulatory organ could be observed separately.

### *Sound recording and Behavioural Observation*

The sounds produced by male spiders during aggressive and sexual interactions were recorded, using an RCA type BK-5A ribbon microphone, attached to a Sony TC-280 tape recorder via a X10 preamplifier. The ribbon microphone is well suited for this kind of work, because it is highly sensitive to near-field sounds, but relatively insensitive to sounds from more distant sources. Recordings of low-intensity sounds produced by small sources (e.g. spiders) can thus be made by placing the sound source sufficiently close to the ribbon diaphragm, without necessitating the use of a special sound-proof room (see BENNET-CLARK, 1972). For these recordings, the microphone and observation chamber were set up as shown in Fig. 1. The microphone, with its outer screen removed, was clam-

ped to a retort stand, facing downwards. The observation chamber, which was a small transparent plastic jar, was attached to the microphone as shown with masking tape. The attachment was made highly flexible, in order to minimise the transmission of substrate vibrations from the chamber to the microphone. The microphone-observation chamber combination was lowered into a glass jar, and the neck stuffed with tissue paper, in order to reduce extraneous airborne background noises. The entire assemblage stood on a 30-kg aluminium slab supported by three tennis-balls, in order to reduce the effect of low-frequency building vibrations.

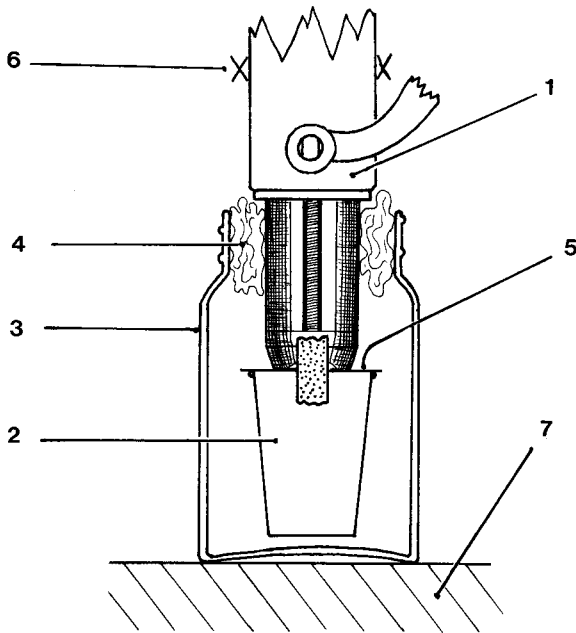

Fig. 1. The microphone and observation chamber assemblage.

1. The microphone, with outer screen removed.
2. The observation chamber, containing spiders.
3. Glass jar.
4. Tissue paper plug.
5. Annular adaptor, made of paper.
6. Position of supporting clamp.
7. 30-kg aluminium base-plate.

During recording, the observation chamber contained two conspecific males, and a conspecific female. This was because it was found during pilot observations that if only one male was present, it tended to remain still, and was unlikely to encounter the female. If two males were present, courtship was more likely to occur. However, in consequence of this experimental design, sounds produced during aggressive interactions between males were recorded as well as courtship sounds. Observation periods lasted for up to 20 minutes.

## Analysis of Sound Recordings

The original tapes were recorded at 17/8 ips and had no more than 20 dB program over noise in the best cases. The signal from these tapes was passed through a graphic equaliser. Frequencies in the 300–1200 Hz band were boosted by 10 dB and all others attenuated by 20 dB. The resultant signals were recorded at 15 ips on a Scully 2-track tape recorder.

The new tapes were played back on a Sony TC 761 tape deck. The samples selected for analysis were digitised using a 14-bit Analog Devices analog-digital converter at a sampling rate of 22,700 Hz producing a set of binary files on a VAX 11-750 computer system. Digitised sound files were played back through a 16-bit Analog Devices digital-analog converter at 22,700 samples/s. The effective overall frequency response was 10 kHz with approximately 80 dB signal to noise ratio. Thus, the limitations of the rather primitive recording apparatus were largely overcome by subsequent processing of the recording.

Each file was read with two different programs:

*SURF* (author: BRIAN HALL). This program will read a digital sound file and will display any desired segment of it as a three-dimensional graph with the following axes:  $x$  = frequency within a selected range;  $y$  = amplitude;  $z$  = time.

*WAVES* (author: COLIN BANGER, modified by JAMES NORTH). This program is an interactive sound file viewer and editor. It will read a digital sound file and display the signal as time vs. amplitude, in a manner similar to an oscilloscope. Of the numerous commands, those used in this analysis include pitch detection (MOORER, 1974), variable time and amplitude scaling, and “envelope display mode”, which plots absolute values of the amplitude averaged over large time segments.

The outputs of these programs were displayed on a Norpak IGP Vector Display Processor with HP display. Samples were photographed with Polaroid 35 mm film.

## RESULTS

### The Scanning Electron Micrographs

SEM's of the stridulatory organs of the two species are shown in Figs. 2–5. (Compare with light micrographs in GWINNER-HANKE, 1970.) The sound is produced by the blunt “tooth-like” protuberances on the abdominal part rubbing over the closely-packed ridges on the cephalothoracic part. Each “tooth” on the abdominal part has a bristle, which may perform a proprioceptive function.

Judging from the eight specimens observed, the stridulatory organs are virtually identical in both species. The abdominal part has two rows of 8 teeth, spaced at intervals of approximately 8  $\mu\text{m}$ . The cephalothoracic part has a series of regularly-spaced transverse ridges, extending approximately 300  $\mu\text{m}$  in the antero-posterior direction. The separation of the ridges is apparently slightly less in *S. bipunctata* (approximately 5  $\mu\text{m}$ ) than in *S. borealis* (approximately 6  $\mu\text{m}$ ).

### Behavioural Observations and Sound Recordings

Spiders were observed to stridulate during aggressive and sexual behaviour. Sexual behaviour only occurred if the observation chamber contained some web, but the web did not have to be produced by the species under observation. *S. bipunctata* would engage in sexual behaviour on web produced by *S. borealis*, and

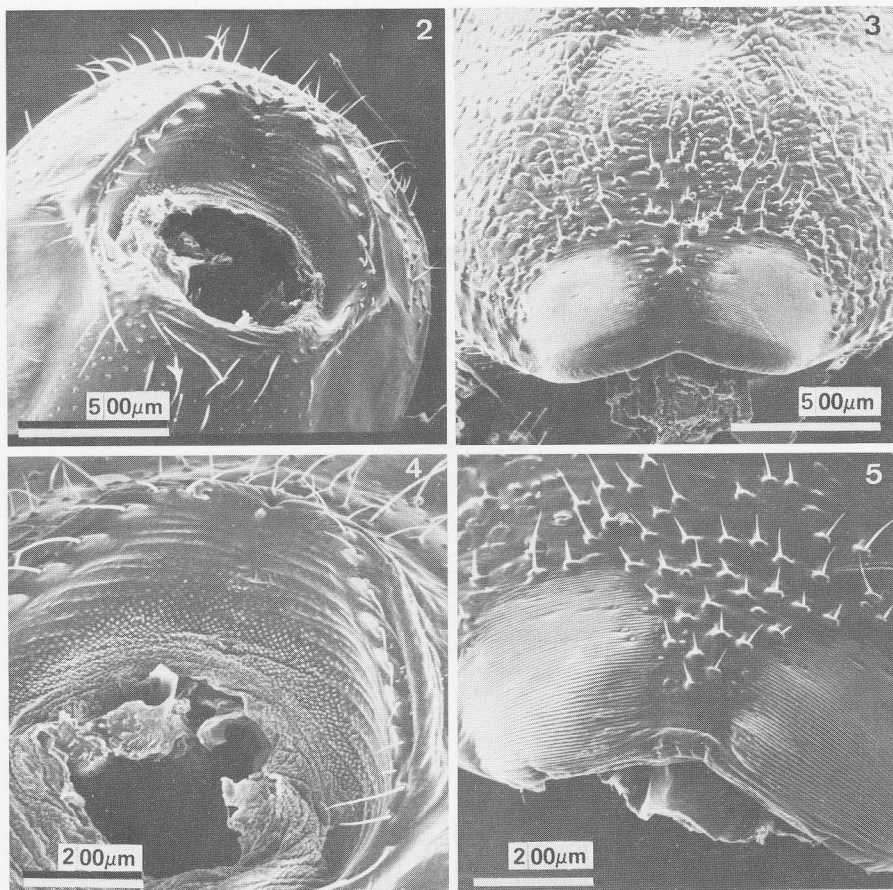

Figs. 2-5. Scanning Electron Micrographs of stridulatory organs of *S. borealis* and *S. bipunctata*.  
 Fig. 2. *S. borealis*, abdominal part.  
 Fig. 3. *S. borealis*, cephalothoracic part.  
 Fig. 4. *S. bipunctata*, abdominal part.  
 Fig. 5. *S. bipunctata*, cephalothoracic part.

vice versa. In each observation period, one male always dominated the other aggressively, produced all the stridulation recorded, and performed all the courtship observed. Thus, the recordings of each observation period contain only the sounds produced by one individual. No differences between sexual and aggressive stridulations were discernible.

20 observation periods were recorded; ten each of *S. bipunctata* and *S. borealis*. However, one of the *S. borealis* males did not produce stridulations loud enough for analysis.

Samples of the loudest sounds recorded from each spider were transferred to a magnetic disc via the analog-digital converter, where they were stored as data files, to be used as input for the "WAVES" and "SURF" programs. A sample

stridulation of each species, as displayed by the output of the two programs, is shown in Figs. 6 and 7.

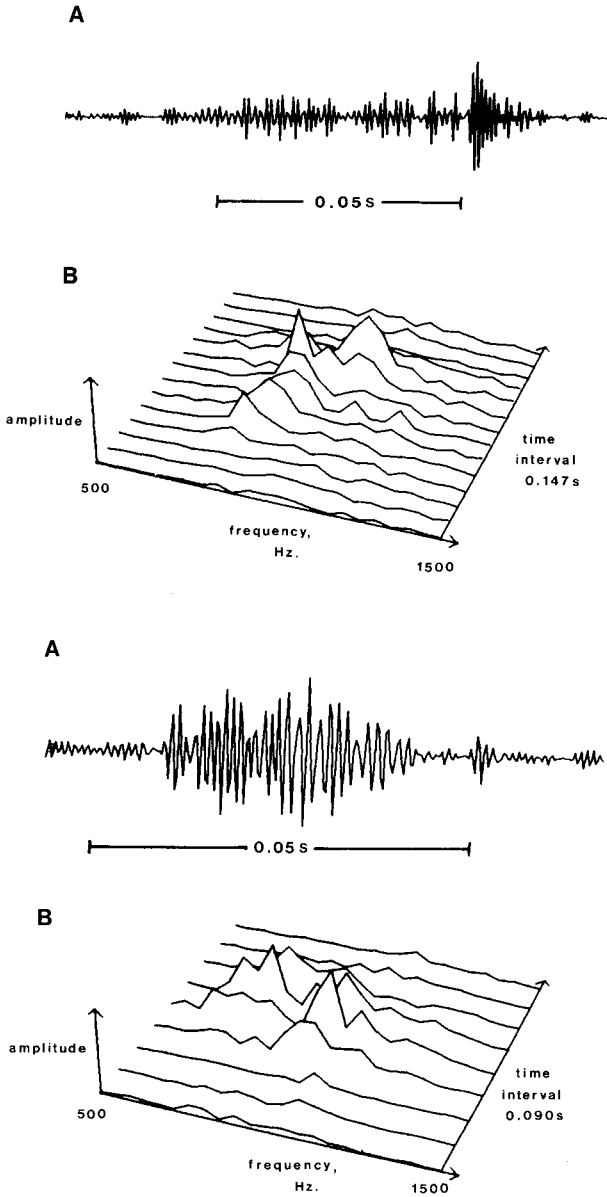

Figs. 6–7. Sample stridulations of *S. bipunctata* and *S. borealis* displayed by WAVES (6a and 7a) and SURF (6b and 7b) programs. 6 = *S. bipunctata* (above); 7 = *S. borealis* (below).

Up to 50 pulses produced by each male were analysed. The following data were taken on each of the pulses analysed: the duration; the mean fundamental frequency with the 500–1200 Hz range over a 0.003s “sample window” taken from the loudest part of the pulse. A random number table was used to choose ten of the analysed pulses from the recordings of each spider for inclusion in the histograms in Figs. 8 and 9. (Nine of the *S. bipunctata* and seven of the *S. borealis* males produced > 10 pulses loud enough for analysis). Where possible, the inter-pulse interval, between the end of one pulse and the beginning of the next, was also measured. (Measurement could be confused by other background noises on the recording, e.g. those produced by spiders walking). Four measured inter-pulse intervals from each spider were chosen at random for inclusion in the histogram in Fig. 10. All three parameters were highly variable in both species, with considerable overlap between the sample populations of the two species’ stridulations. Moreover, it will be seen from Figs. 6 and 7 that each pulse contained a wide mix

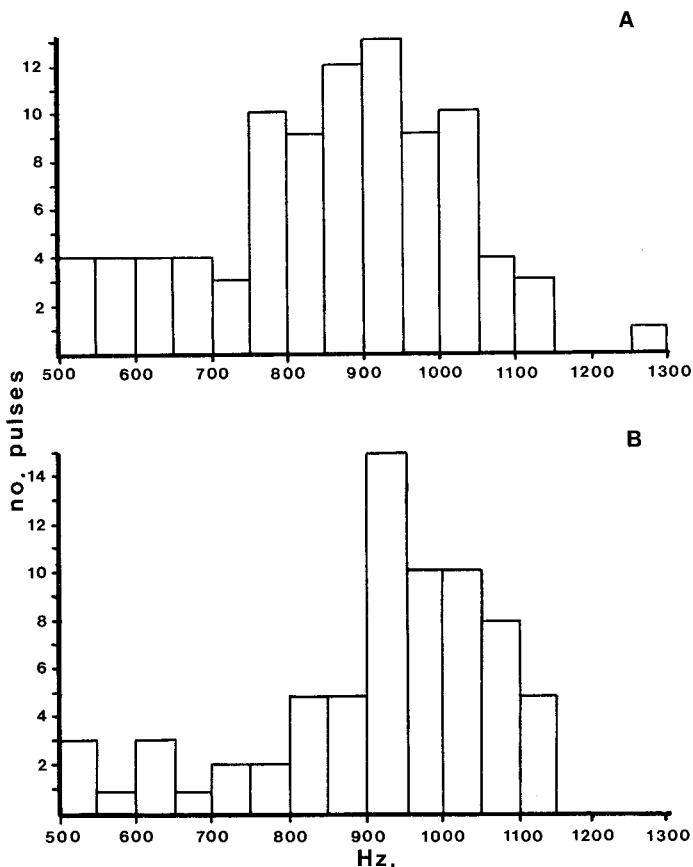

Fig. 8. Histograms of sample fundamental frequencies. A: *S. bipunctata*. B: *S. borealis*.



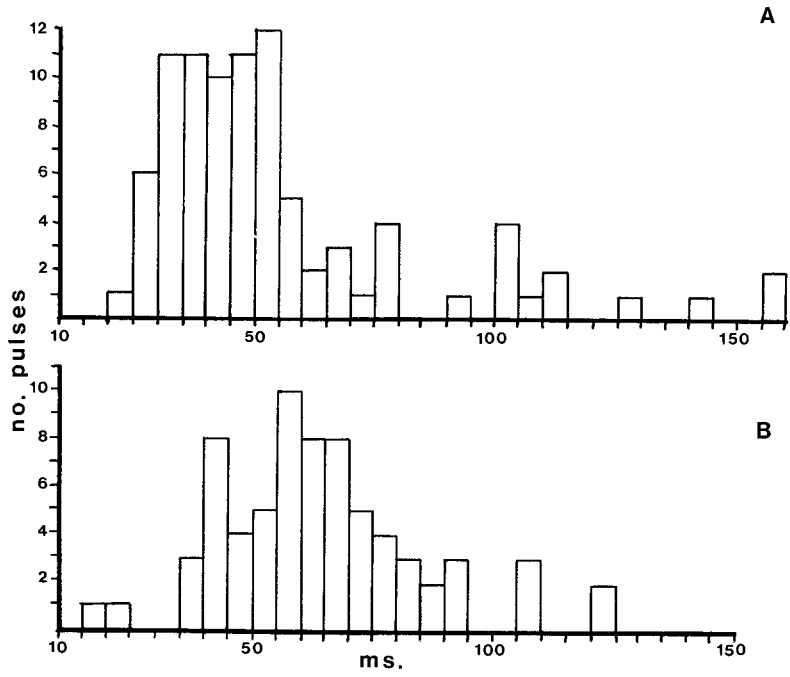

Fig. 9. Histograms of sample pulse durations. A: *S. bipunctata*. B: *S. borealis*.

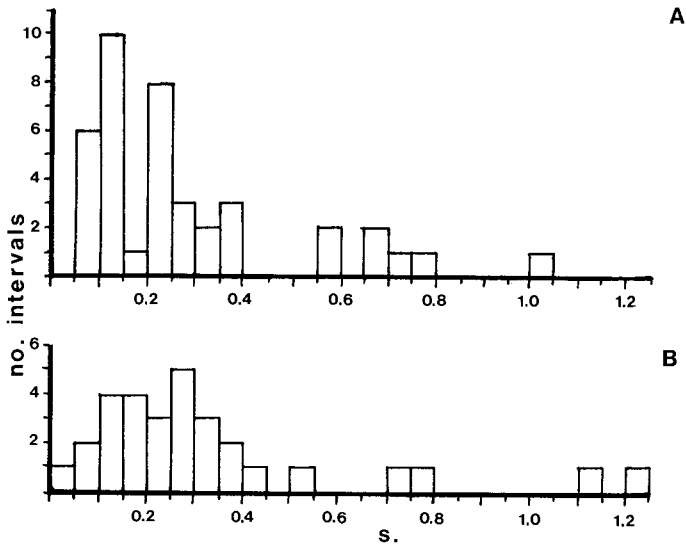

Fig. 10. Histograms of sample inter-pulse intervals. A: *S. bipunctata*. B: *S. borealis*.

Table 1. Fundamental frequencies, pulse durations, and inter-pulse intervals in *S. borealis* and *S. bipunctata*

	Fundamental frequency	Pulse duration	Inter-pulse interval
$\bar{X}$	942 Hz	0.068 s	0.282 s
S.E.	50 Hz	0.009 s	0.105 s
N	119	119	52
<hr/>			
$\bar{X}$	869 Hz	0.053 s	0.291 s
S.E.	52 Hz	0.007 s	0.078 s
N	206	206	112

Table 2. Anovar tables of Fundamental Frequencies, Pulse Periods, and Inter-Pulse Intervals

Source of Variation	Fundamental Frequencies, Hz			Pulse Periods, s.			Inter-Pulse Intervals, s.					
	df	SS	MS	Fs	df	SS	MS	Fs	df	SS	MS	Fs
between species	1	437537	437537	13.1*	1	0.0112	0.0112	1.03	1	0.0005	0.0005	0.003
between individuals	17	566860	33345	1.33	17	0.186	0.011	288*	15	2.978	0.198	2.964*
within individuals	306	769557	25149		306	0.0116	0.00004		141	9.445	0.067	

\*  $P < 0.01$

of frequencies. Thus, the concept of a pulse having a "fundamental frequency" is a considerable simplification. There were no signs of consistent peak frequencies. Therefore, the frequencies measured are believed to have been those inherent in the stridulations, and not resonance frequencies of the apparatus or observation chamber.

All the sound pulses measured were included in the statistical analyses of the fundamental frequencies, pulse periods, and inter-pulse intervals. Means and standard errors of these parameters for the two species are given in Table 1. Analysis was by two-level nested anovars (e.g. see Sokal & Rohlf, 1969, pp. 274–281). The anova tables are given in Table 2. Overall mean carrier frequencies were found to differ significantly between species, but the difference is small compared with the range of variation found within individuals. Mean pulse periods and inter-pulse intervals differed highly between individuals, but not between species.

## DISCUSSION

Males of the American populations of *S. bipunctata* and *S. borealis* both produce stridulations with fundamental frequencies typically ranging between 750 and 1100 Hz. This range is consistent with the estimated 800–1000 Hz reported by GWINNER-HANKE (1970). Thus, geographical isolation of the American population of *S. bipunctata* from its ancestral European population appears not to have been accompanied by divergence in sound characteristics as has been reported in some populations of drosophilid flies (e.g. IKEDA *et al.*, 1980).

The range of frequencies found, both within and between pulses, is very wide (about 1.5 octaves in musical terms). Although the mean fundamental frequencies apparently differ between the two species, the frequency ranges overlap so much that it seems unlikely that they could be used as a cue for species recognition. The ranges of the pulse durations also appear to overlap completely. If either species was using either of these parameters for species recognition, narrower ranges, with little or no overlap, would be expected. Also one would expect clear-cut differences between aggressive and courtship stridulations, since courtship stridulations would be under a selection pressure for species-specificity, while aggressive stridulation might not be. SCHWARTZ & WELLS (1984) report that three sympatric species of tree-frog (genus *Hyla*) have aggressive calls which are not species-specific, and show considerable intraspecific variation. Their "advertisement" (sexual) calls, however, vary little, are highly species-specific, and differ markedly from the aggressive calls; they are apparently used for species recognition.

These findings are consistent with those reported by NYFFELER *et al.* (1986), that the pre-mating reproductive barrier between these species is apparently a mechanical one. Females of both species are receptive to courtships of both conspecific and heterospecific males. Males of both species will attempt copulation with heterospecific females, but the differences in the morphology of the two species' external copulation organs prevents successful insertion of the embolus into the female epigynum.

A reproductive barrier such as this, which does not act until a very late stage of courtship, is inefficient compared with that apparently operating between the sympatric sibling species of wolf spider *Schizocosa rovnieri* (UETZ & DONDALE) and *S. ocreata* (HENTZ) (STRATTON & UETZ, 1981, 1983; UETZ & STRATTON, 1982). Their external copulation organs are identical, but interspecific copulation

does not occur. Species-specific male courtship sounds have been shown to act as recognition cues. These two species have co-existed for a long time. The geographical ranges of the two *Steatoda* species studied here have only overlapped for about one hundred years. Moreover, circumstantial evidence has been found suggesting that where the two species co-exist, *S. bipunctata* tends to displace *S. borealis* (NYFFELER *et al.*, 1986). Mixed populations may thus be a very temporary phenomenon. Thus, there may be relatively little selection pressure for a more efficient pre-mating barrier.

#### ACKNOWLEDGEMENTS

This research made use of facilities at the following institutions: the Biosystematics Research Institute, Ottawa (collection of spiders, observations, scanning electron microscopy); Queen's University Department of Biology (observations and sound recordings); Queen's University Department of Music and Department of Computing and Information Science (processing and analysis of recordings). R. LEE held a Fellowship awarded by the Royal Commission for the exhibition of 1851, London. M. NYFFELER held a Postdoctoral Fellowship awarded by the Swiss National Science Foundation (Research Commission of the Swiss Federal Institute of Technology, Zurich) for a stay in Canada.

The authors wish to thank Professor P. COLGAN for advice on the statistical analyses. Valuable advice and comments on the manuscript were provided by Professor R. HARMSEN, Dr. C. DONDALE, and Dr. H. C. BENNET-CLARK. Finally, the authors are grateful to Mr. J. H. REDNER for help in collecting spiders and Dr. R. ANDERSON for permission to use the scanning electron microscope of the B.R.I.

#### ZUSAMMENFASSUNG

*Steatoda bipunctata* und *S. borealis* sind zwei nahe verwandte Spinnenarten, die für lange Zeit total allopatrisch waren. Im letzten Jahrhundert wurde *S. bipunctata* ins Verbreitungsgebiet von *S. borealis* eingeführt, wo sie sich seither ausgebreitet hat. Reproduktive Isolation zwischen den beiden Arten resultiert scheinbar daraus, dass ihre Kopulationsapparate nicht zusammenpassen. In dieser Arbeit wurden die Stridulationsorgane der Männchen beschrieben sowie die während sexuellem und agonistischem Verhalten produzierten Töne analysiert. Die interspezifischen Unterschiede der Töne sind klein verglichen mit der Spannweite der Variation innerhalb der Art. Die Stridulationsorgane der beiden Arten sind extrem ähnlich. Es besteht kein Beweis dafür, dass artspezifische Unterschiede zwischen den von Männchen produzierten Tönen für die Artenerkennung verwendet werden könnten. Dies steht im Gegensatz zu Arten, die über längere Zeit koexistiert haben und die scheinbar artspezifische Töne als Erkennungsmechanismus verwenden.

#### REFERENCES

- ALLARD, H. A. 1936. *The drumming spider (Lycosa gulosa WALCKENAER)*. Proc. Biol. Soc. Washington 49: 67–68.
- BENNET-CLARK, H. C. 1972. *Microphone and pre-amplifier for recording courtship song in Drosophila*. Dros. Inf. Serv. 49: 127.
- BUCKLE, D. J. 1972. *Sound production in the courtship of two lycosid spiders, Schizocosa avida (WALCK.) and Tarentula aculea (CL.)*. Blue Jay 30: 110–113.
- DAVIS, W. T. 1904. *Spider calls*. Psyche 11: 120.
- EDWARDS, G. B. 1981. *Sound production by courting males of Phydippis mystaceus (Araneae: Salticidae)*. Psyche 88: 199–214.
- GERTSCH, W. J. 1979. *American Spiders*. Van Nostrand, New York.
- GWINNER-HANKE, H. 1970. *Zum Verhalten zweier stridulierender Spinnen Steatoda bipunctata LINNE und Teutana grossa KOCH (Theridiidae, Araneae), unter besonderer Berücksichtigung des Fortpflanzungsverhaltens*. Z. Tierpsychol. 27: 649–678.
- HARRISON, J. B. 1969. *Acoustic behaviour of a wolf spider, Lycosa gulosa*. Anim. Behav. 17: 371–390.
- IKEDA, H., TAKABATAKE, I., & SAWADA, N. 1980. *Variation in courtship sounds among three geographical strains of Drosophila mercatorum*. Behav. Genet. 10: 361–375.
- LAHEE, F. H. 1904. *The calls of spiders*. Psyche 11: 74.
- LEVI, H. W. 1957. *The spider genera Crustulina and Steatoda in North America, Central America, and the West Indies (Araneae, Theridiidae)*. Bull. Mus. Comp. Zool. 117: 367–424.

- MOORER, J. A. 1974. *The optimum comb method of pitch period analysis of continuous digitized speech*. IEEE Transactions on Acoustics, Speech and Signal Processing, Vol. TASSP-22 (5): 330–338.
- NYFFELER, M., DONDALE, C. D. & REDNER, J. H. 1986. *Evidence for displacement of a North American spider, Steatoda borealis (HENTH), by the European species S. bipunctata (LINNAEUS) (Araneae: Theridiidae)*. Canadian Journal of Zoology 64: 867–874.
- PRELL, H. 1916. *Über trommelnde Spinnen*. Zool. Anz. 48: 61–64.
- ROVNER, J. S. 1967. *Acoustic communication in a lycosid spider Lycosa rabida (WALCKENAER)*. Anim. Behav. 15: 273–281.
- ROVNER, J. S. 1975. *Sound production by Nearctic wolf spiders: a substratum-coupled stridulatory mechanism*. Science (N.Y.) 190: 1309–1310.
- ROVNER, J. S. 1980. *Vibration in Heteropoda venatoria (Sparassidae): a third method of sound production in spiders*. J. Arachnol. 8: 193–200.
- SCHWARTZ, J. J., & WELLS, K. D. 1984. *Interspecific acoustic interactions of the neotropical tree-frog Hyla ebraccata*. Behav. Ecol. Sociobiol. 14: 211–224.
- SOKAL, R. R., & ROHLE, F. J. 1969. *Biometry. The principles and practice of statistics in biological research*. W. H. Freeman & Co., San Francisco.
- STRATTON, G. E. & UETZ, G. W. 1981. *Acoustic communication and reproductive isolation in two species of wolf spiders*. Science (N.Y.) 214: 575–577.
- STRATTON, G. E. & UETZ, G. W. 1983. *Communication via substratum-coupled stridulation and reproductive isolation in wolf spiders (Araneae: Lycosidae)*. Anim. Behav. 31: 164–172.
- UETZ, G. W., & STRATTON, G. E. 1982. *Acoustic communication and reproductive isolation in spiders*. In: Spider communication. Mechanisms and ecological significance (eds. P. N. WITT & J. S. ROVNER). Princeton University Press, Princeton, New Jersey.
- WIEHLE, H. 1937. *Theridiidae oder Haubennetzspinnen (Kugelspinnen)*. Tierwelt Deutschlands, 33. G. Fischer-Verlag, Jena.

(received July 10, 1986)