



Conference Paper

## **An importance sampling algorithm for the Ising model with strong couplings**

**Author(s):**

Molkaraie, Mehdi

**Publication Date:**

2016

**Permanent Link:**

<https://doi.org/10.3929/ethz-a-010645962> →

**Rights / License:**

[In Copyright - Non-Commercial Use Permitted](#) →

This page was generated automatically upon download from the [ETH Zurich Research Collection](#). For more information please consult the [Terms of use](#).

# An Importance Sampling Algorithm for the Ising Model with Strong Couplings

Mehdi Molkaiaie

Dept. of Information and Communication Technologies

ETH Zurich

8092 Zürich, Switzerland

mehdi.molkaiaie@alumni.ethz.ch

**Abstract**—We consider the problem of estimating the partition function of the two-dimensional ferromagnetic Ising model in an external magnetic field. The estimation is done via importance sampling in the dual of the Forney factor graph representing the model. Emphasis is on models at low temperature (corresponding to models with strong couplings) and on models with a mixture of strong and weak coupling parameters.

## I. INTRODUCTION

The problem of estimating the partition function of the finite-size two-dimensional (2D) ferromagnetic Ising model in a consistent external field is considered. Applying factor graph duality to address the problem has been investigated in [1]–[4]. It was demonstrated in [1] that Monte Carlo methods based on the dual factor graph work very well for the Ising model at low temperature. In contrast, Monte Carlo methods in the primal/original graph suffer from critical slowing down and erratic convergence to estimate the partition function in the low-temperature regime [5]. Monte Carlo methods (based on uniform sampling and Gibbs sampling) in the dual factor graph were also proposed in [1] to estimate the partition function of the 2D Ising model without an external field.

In this paper, we continue this research to extend the results of [1], [2] to models with a mixture of strong and weak coupling parameters and in the presence of an external magnetic field. After defining an auxiliary probability mass function in the dual Forney factor graph of the model, we propose an importance sampling algorithm that can efficiently estimate the partition function. A similar importance sampling algorithm, designed specifically for models in a strong external field, was recently proposed in [2].

The paper is organized as follows. We review the Forney factor graph representation of the 2D Ising model in an external field in Section II. Section III discusses dual Forney factor graphs and the normal factor graph duality theorem. The importance sampling algorithm is described in Section IV. In Section V, we report numerical experiments.

## II. THE ISING MODEL IN AN EXTERNAL MAGNETIC FIELD

Let  $X_1, X_2, \dots, X_N$  be a set of discrete binary random variables arranged on the sites of a 2D lattice. We suppose that interactions are restricted to adjacent (nearest-neighbor) variables (see Fig. 1). The real coupling parameter  $J_{k,\ell}$  controls the strength of the interaction between adjacent variables

$(X_k, X_\ell)$ . The real parameter  $H_m$  corresponds to the presence of an external field and controls the strength of the interaction between  $X_m$  and the field. Each random variable takes on values in  $\mathcal{X} = \{0, 1\}$ . Let  $x_i$  represent a possible realization of  $X_i$ ,  $\mathbf{x}$  stand for a configuration  $(x_1, x_2, \dots, x_N)$ , and  $\mathbf{X}$  stand for  $(X_1, X_2, \dots, X_N)$ .

The energy of a configuration  $\mathbf{x}$  is given by [6]

$$\mathcal{H}(\mathbf{x}) = - \sum_{(k,\ell) \in \mathcal{B}} J_{k,\ell} \cdot ([x_k = x_\ell] - [x_k \neq x_\ell]) - \sum_{m=1}^N H_m \cdot ([x_m = 1] - [x_m = 0]) \quad (1)$$

where  $\mathcal{B}$  contains all the unordered pairs (bonds)  $(k, \ell)$  with non-zero interactions, and  $[\cdot]$  denotes the Iverson bracket [7], which evaluates to 1 if the condition in the bracket is satisfied and to 0 otherwise.

In this paper, the focus is on ferromagnetic Ising models characterized by  $J_{k,\ell} > 0$  for each  $(k, \ell) \in \mathcal{B}$ . The external field is assumed to be consistent, i.e., it is either assigned to all positive or to all negative values.

The probability that the model is in configuration  $\mathbf{x}$  is given by the Boltzmann distribution [6]

$$p_{\mathcal{B}}(\mathbf{x}) = \frac{e^{-\beta \mathcal{H}(\mathbf{x})}}{Z} \quad (2)$$

where the normalization constant  $Z$  is the *partition function*  $Z = \sum_{\mathbf{x} \in \mathcal{X}^N} e^{-\beta \mathcal{H}(\mathbf{x})}$  and  $\beta$  is the inverse temperature. In the rest of this paper, we assume  $\beta = 1$ . With this assumption, large values of  $J$  correspond to models at low temperature. Boundary conditions are assumed to be periodic.

For each adjacent pair  $(x_k, x_\ell)$ , let  $\kappa : \mathcal{X}^2 \rightarrow \mathbb{R}_{>0}$

$$\kappa_{k,\ell}(x_k, x_\ell) = e^{J_{k,\ell} \cdot ([x_k = x_\ell] - [x_k \neq x_\ell])} \quad (3)$$

and for each  $x_m$ , let  $\tau : \mathcal{X} \rightarrow \mathbb{R}_{>0}$

$$\tau_m(x_m) = e^{H_m \cdot ([x_m = 1] - [x_m = 0])} \quad (4)$$

We then define  $f : \mathcal{X}^N \rightarrow \mathbb{R}_{>0}$  as

$$f(\mathbf{x}) \triangleq \prod_{(k,\ell) \in \mathcal{B}} \kappa_{k,\ell}(x_k, x_\ell) \prod_{m=1}^N \tau_m(x_m) \quad (5)$$

The corresponding Forney factor graph (normal graph) for the factorization in (5) is shown in Fig. 1, where the boxes labeled “=” are equality constraints [8], [9]. In Forney factor graphs variables are represented by edges.

From (5),  $Z$  in (2) can also be expressed as

$$Z = \sum_{\mathbf{x} \in \mathcal{X}^N} f(\mathbf{x}) \quad (6)$$

At high temperature (i.e., for small  $J$ ), the Boltzmann distribution (2) approaches the uniform distribution. In this case, Monte Carlo methods for estimating  $Z$  usually perform well in the primal factor graph. Estimating  $Z$  in the low-temperature regime is more challenging [5], [10], [11].

In this paper, we consider models at low temperature (i.e., with large  $J$ ) and models with a mixture of strong and weak coupling parameters in an external magnetic field. To compute an estimate of  $Z$  in this case, we propose an importance sampling algorithm in the dual of the Forney factor graph of the 2D Ising model.

### III. THE DUAL FORNEY FACTOR GRAPH

We can obtain the dual of the Forney factor graph in Fig. 1, by replacing each binary variable  $x$  with its dual binary variable  $\tilde{x}$ , each factor  $\kappa_{k,\ell}$  with its 2D Discrete Fourier transform (DFT), each factor  $\tau_m$  with its one-dimensional (1D) DFT, and each equality constraint with an XOR factor, cf. [8], [12]–[14]. Fig. 2 shows the dual Forney factor graph of the 2D Ising model, where boxes containing “+” symbols represent XOR factors as

$$g(\tilde{x}_1, \tilde{x}_2, \dots, \tilde{x}_k) = [\tilde{x}_1 \oplus \tilde{x}_2 \oplus \dots \oplus \tilde{x}_k = 0] \quad (7)$$

the small boxes attached to each XOR factor are given by

$$\lambda_m(\tilde{x}_m) = \begin{cases} \cosh H_m, & \text{if } \tilde{x}_m = 0 \\ -\sinh H_m, & \text{if } \tilde{x}_m = 1 \end{cases} \quad (8)$$

and the unlabeled normal-size boxes attached to each equality constraint represent factors as

$$\gamma_k(\tilde{x}_k) = \begin{cases} 2 \cosh J_k, & \text{if } \tilde{x}_k = 0 \\ 2 \sinh J_k, & \text{if } \tilde{x}_k = 1 \end{cases} \quad (9)$$

Here,  $J_k$  is the coupling parameter associated with each bond. See [1]–[3], for more details on constructing the dual Forney factor graph of the 2D Ising model.

In the dual domain, we denote the partition function by  $Z_d$ . For the models that we study here, the normal factor graph duality theorem states that (see [13, Theorem 2])

$$Z_d = |\mathcal{X}^N| Z \quad (10)$$

In order to design Monte Carlo methods in the dual Forney graph, we require factors (8) and (9) to be non-negative. In a 2D Ising model,  $Z$  is invariant under the change of sign of the external field [6]. Therefore, without loss of generality, we will assume  $H_m < 0$  for  $1 \leq m \leq N$ . Under the ferromagnetic assumption  $J_{k,\ell} > 0$  for  $(k, \ell) \in \mathcal{B}$ . With these assumptions, (8) and (9) will be non-negative.

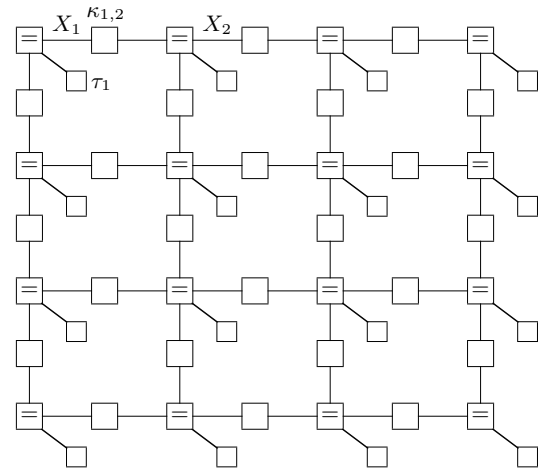

Fig. 1: Forney factor graph of the 2D Ising model in an external field, where unlabeled normal-size boxes represent (3), small boxes represent (4), and boxes containing “=” symbols are equality constraints.

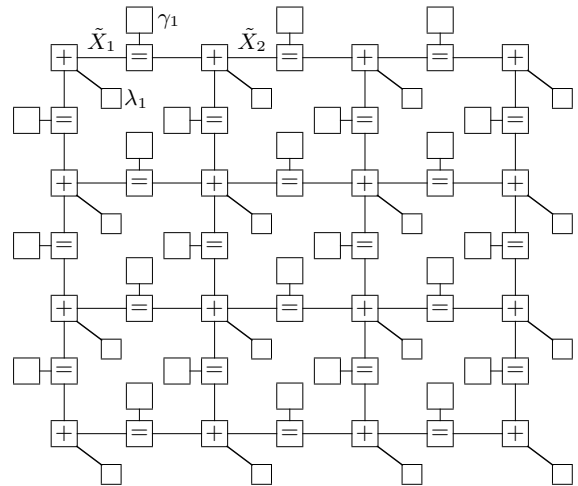

Fig. 2: The dual Forney factor graph of the 2D Ising model in an external field, where boxes containing “+” symbols represent (7), small boxes represent (8), and unlabeled normal-size boxes represent (9).

### IV. THE IMPORTANCE SAMPLING ALGORITHM

The importance sampling algorithm is described on Fig. 2. We partition  $\tilde{\mathcal{X}}$  into  $\tilde{\mathcal{X}}_A$  and  $\tilde{\mathcal{X}}_B$ , with the condition that  $\tilde{\mathcal{X}}_B$  is a linear combination (involving the XOR factors) of  $\tilde{\mathcal{X}}_A$ . In this set-up, a valid configuration in the dual factor graph can be created by assigning values to  $\tilde{\mathcal{X}}_A$ , followed by computing  $\tilde{\mathcal{X}}_B$  as a linear combination of  $\tilde{\mathcal{X}}_A$ .

An example of such a partitioning is shown in Fig. 3, where  $\tilde{\mathcal{X}}_A$  is the set of all the variables associated with the thick edges and  $\tilde{\mathcal{X}}_B$  the set of all the variables associated with the remaining thin edges. Accordingly, let  $\mathcal{B}_A \subset \mathcal{B}$  contain the indices of the bonds marked by thick edges and  $\mathcal{B}_B = \mathcal{B} - \mathcal{B}_A$ . For a valid configuration  $\tilde{\mathbf{x}} = (\tilde{\mathbf{x}}_A, \tilde{\mathbf{x}}_B)$ , let

$\tilde{\mathbf{x}}_A = (\tilde{\mathbf{y}}, \tilde{\mathbf{z}})$ , where  $\tilde{\mathbf{y}}$  contains all the thick edges attached to the small unlabeled boxes (involved in (8)) and  $\tilde{\mathbf{z}}$  contains all the variables associated with the thick bonds (involved in (9)).

We prove that  $w_H(\tilde{\mathbf{y}})$ , the Hamming weight of  $\tilde{\mathbf{y}}$ , is always even, where the Hamming weight of a vector is the number of non-zero components of that vector [15].

**Lemma 1.** If  $\tilde{\mathbf{x}}$  is a valid configuration in the dual Forney factor graph, then  $w_H(\tilde{\mathbf{y}})$  is even.

*Proof.* We consider  $c = \bigoplus_{t=1}^N \tilde{y}_t$  the component-wise XOR of  $\tilde{\mathbf{y}}$ . Each XOR factor imposes the constraint that all its incident variables sum to 0 in GF(2). Each  $\tilde{y}_t$  in  $c$  can thus be expanded as the XOR of the corresponding variables associated with the bonds, furthermore, the variables on the bonds each appear twice in this expansion. Hence  $c = 0$ , i.e.,  $w_H(\tilde{\mathbf{y}})$  is even. ■

Lemma 1 implies that  $Z_d$ , and thus  $Z$  itself, are invariant under the change of sign of  $H_m$ . Indeed, regardless of the sign of  $H_m$ , i.e., assigned to all positive or to all negative values  $\prod_{m=1}^N \lambda_m(\tilde{x}_m)$  takes the same positive value, cf. (8).

The importance sampling algorithm works as follows. To draw  $\tilde{\mathbf{x}}^{(\ell)}$  at each iteration  $\ell$ , we first draw  $\tilde{\mathbf{x}}_A^{(\ell)}$  according to a suitably defined auxiliary probability mass function on the bonds (see (13)). We then update  $\tilde{\mathbf{x}}_B^{(\ell)}$  to create a valid configuration  $\tilde{\mathbf{x}}^{(\ell)} = (\tilde{\mathbf{x}}_A^{(\ell)}, \tilde{\mathbf{x}}_B^{(\ell)})$ . Updating  $\tilde{\mathbf{x}}_B^{(\ell)}$  at each iteration is easy as  $\tilde{\mathbf{x}}_B$  is a linear combination of  $\tilde{\mathbf{x}}_A$ .

Let us define

$$\Lambda(\tilde{\mathbf{x}}_B) \triangleq \prod_{k \in \mathcal{B}_B} \gamma_k(\tilde{x}_k) \quad (11)$$

$$\Psi(\tilde{\mathbf{x}}_A) \triangleq \prod_{k \in \mathcal{B}_A} \gamma_k(\tilde{x}_k) \prod_{m=1}^N \lambda_m(\tilde{x}_m) \quad (12)$$

$$q(\tilde{\mathbf{x}}_A) \triangleq \frac{\Psi(\tilde{\mathbf{x}}_A)}{Z_q}, \quad \forall \tilde{\mathbf{x}}_A \in \mathcal{X}^{|\mathcal{B}_A|} \quad (13)$$

where  $Z_q$  in (13) is available as

$$Z_q = \sum_{\tilde{\mathbf{x}}_A} \Psi(\tilde{\mathbf{x}}_A) = 2^{|\mathcal{B}_A|} \exp\left(\sum_{k \in \mathcal{B}_A} J_k - \sum_{m=1}^N H_m\right) \quad (14)$$

Here  $|\mathcal{B}_A|$  is the cardinality of  $\mathcal{B}_A$ . Note that  $H_m < 0$ .

The product form of (12) suggests that to draw a sample  $\tilde{\mathbf{x}}_A^{(\ell)} = (\tilde{\mathbf{y}}^{(\ell)}, \tilde{\mathbf{z}}^{(\ell)})$  according to  $q(\tilde{\mathbf{x}}_A)$ , two separate subroutines are required, one for the  $\tilde{\mathbf{y}}^{(\ell)}$ -part, and another for the  $\tilde{\mathbf{z}}^{(\ell)}$ -part. To draw the  $\tilde{\mathbf{y}}^{(\ell)}$ -part, we apply.

**repeat**

*draw*  $u_1^{(\ell)}, u_2^{(\ell)}, \dots, u_N^{(\ell)} \stackrel{\text{i.i.d.}}{\sim} \mathcal{U}[0, 1]$

**for**  $m = 1$  **to**  $N$

**if**  $u_m^{(\ell)} < \frac{1}{2}(1 + e^{2H_m})$

$\tilde{y}_m^{(\ell)} = 0$

**else**

$\tilde{y}_m^{(\ell)} = 1$

**end if**

**end for**

**until**  $w_H(\tilde{\mathbf{y}}^{(\ell)})$  is even

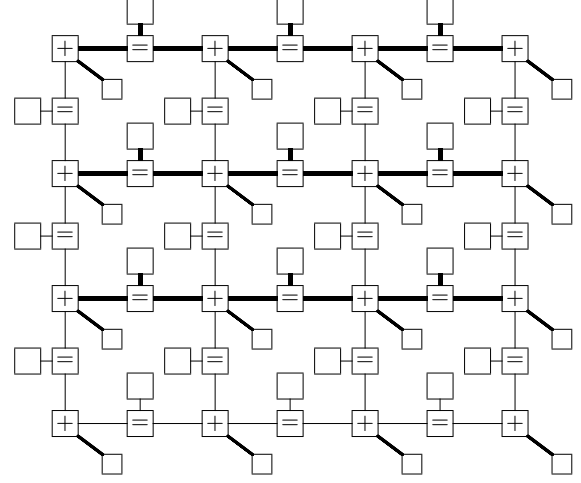

Fig. 3: A partitioning of variables in the dual Forney factor graph of the 2D Ising model. The thick edges represent  $\tilde{\mathbf{X}}_A$  and the remaining thin edges represent  $\tilde{\mathbf{X}}_B$ .

The criteria to accept  $\tilde{\mathbf{y}}^{(\ell)}$  is based on Lemma 1. The quantity  $\frac{1}{2}(1 + e^{2H_m})$  is equal to  $\lambda_m(0)/(\lambda_m(0) + \lambda_m(1))$ . To draw the  $\tilde{\mathbf{z}}^{(\ell)}$ -part, the following subroutine is applied.

*draw*  $u_1^{(\ell)}, u_2^{(\ell)}, \dots, u_{|\mathcal{B}_A|}^{(\ell)} \stackrel{\text{i.i.d.}}{\sim} \mathcal{U}[0, 1]$

**for**  $k = 1$  **to**  $|\mathcal{B}_A|$

**if**  $u_k^{(\ell)} < \frac{1}{2}(1 + e^{-2J_k})$

$\tilde{z}_k^{(\ell)} = 0$

**else**

$\tilde{z}_k^{(\ell)} = 1$

**end if**

**end for**

Here,  $\frac{1}{2}(1 + e^{-2J_k})$  is equal to  $\gamma_k(0)/(\gamma_k(0) + \gamma_k(1))$ . We can then create  $\tilde{\mathbf{x}}_A^{(\ell)}$  as a concatenation of  $\tilde{\mathbf{y}}^{(\ell)}$  and  $\tilde{\mathbf{z}}^{(\ell)}$ .

It is possible to compute the probability of rejection in the algorithm. E.g., if the model is in a constant external field  $H$

$$P(w_H(\tilde{\mathbf{y}}) \text{ is odd}) = \sinh(N|H|)e^{-N|H|} \quad (15)$$

$$\leq 0.5 \quad (16)$$

The two previous subroutines will provide *i.i.d.* samples  $\tilde{\mathbf{x}}_A^{(1)}, \tilde{\mathbf{x}}_A^{(2)}, \dots, \tilde{\mathbf{x}}_A^{(\ell)}, \dots$  according to (13). Updating  $\tilde{\mathbf{x}}_B^{(\ell)}$  is easy after generating  $\tilde{\mathbf{x}}_A^{(\ell)}$ . The created samples are then used in the following importance sampling algorithm in order to estimate  $Z_d$ .

**for**  $\ell = 1$  **to**  $L$

*draw*  $\tilde{\mathbf{x}}_A^{(\ell)}$  according to  $q(\tilde{\mathbf{x}}_A)$

*update*  $\tilde{\mathbf{x}}_B^{(\ell)}$

**end for**

*compute*

$$\hat{Z}_{\text{IS}} = \frac{Z_q}{L} \sum_{\ell=1}^L \Lambda(\tilde{\mathbf{x}}_B^{(\ell)}) \quad (17)$$

**Lemma 2.**  $\hat{Z}_{\text{IS}}$  is an unbiased estimator of  $Z_d$ .

*Proof.*

$$\begin{aligned} \mathbb{E}_q[\hat{Z}_{\text{IS}}] &= \mathbb{E}_q \left[ \frac{Z_q}{L} \sum_{\ell=1}^L \Lambda(\tilde{\mathbf{X}}_B^{(\ell)}) \right] \\ &= Z_q \cdot \mathbb{E}_q [\Lambda(\tilde{\mathbf{X}}_B)] \\ &= \sum_{\tilde{\mathbf{x}}_A} \Psi(\tilde{\mathbf{x}}_A) \cdot \Lambda(\tilde{\mathbf{x}}_B) \\ &= Z_d \end{aligned}$$

■

The estimate of  $Z_d$  is then used to compute a Monte Carlo estimate of  $Z$ , as in (6), via the normal factor graph duality theorem (cf. Section III).

The accuracy of (17) depends on the fluctuations of  $\Lambda(\tilde{\mathbf{x}}_B)$ . If  $\Lambda(\tilde{\mathbf{x}}_B)$  varies smoothly,  $\hat{Z}_{\text{IS}}$  will have a small variance. From (9) and (11), we expect to observe a small variance if  $J_k$  is large for  $k \in \mathcal{B}_B$  – as for large values of  $J_k$ , each factor (9) tends to a constant factor. For more details, see [4].

We emphasize that our choice of partitioning in Fig. 3 is not unique. Fig. 4 shows another example of a partitioning in the dual Forney factor graph whose corresponding partitioning in the primal factor graph is not cycle-free. A partitioning which gives rise to a slightly different importance sampling algorithm (with no rejections) is discussed in [4].

The proposed algorithm is applicable to the Ising model in the absence of an external field as well. Indeed, partitionings in Figs. 3 and 4 are valid even when the external field is not present. We will consider Ising models without an external field in our numerical experiments in Section V-A.

That being the case, to observe fast convergence in the dual domain, not all the coupling parameters need to be strong, but a restricted subset of them. The method of this paper can thus be regarded as supplementary to the ones presented in [1] and [2], where the focus is on models at low temperature (corresponding to models in which all the coupling parameters are strong) and on models in a strong external field.

## V. NUMERICAL EXPERIMENTS

We apply the importance sampling algorithm to estimate the log partition function per site, i.e.,  $\frac{1}{N} \ln Z$ , of 2D Ising models. All simulation results show  $\frac{1}{N} \ln Z$  vs. the number of samples for *one instance*<sup>1</sup> of the model with periodic boundaries.

We consider 2D ferromagnetic Ising models with spatially varying (edge-dependent) coupling parameters without an external field in Section V-A. We will also compare the efficiency of the importance sampling algorithm with uniform sampling. Comparisons with Gibbs sampling and the Swendsen-Wang algorithm [16] are discussed in [4]. 2D ferromagnetic Ising models in an external field with spatially varying model parameters are considered in Section V-B.

<sup>1</sup>In statistical physics, estimating quantities for a fixed set of couplings (generated according to some distribution) is called the “quenched average”.

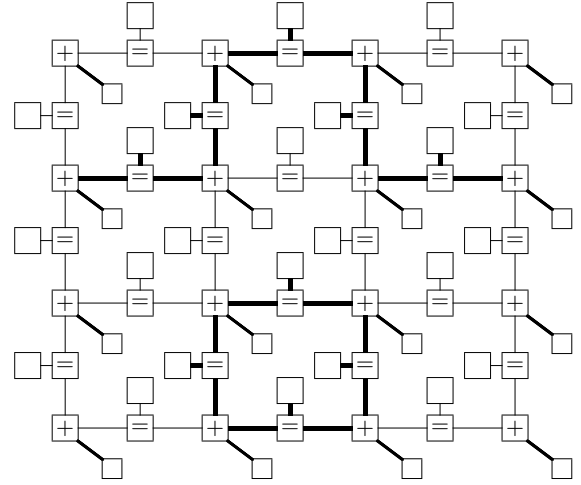

Fig. 4: Another example of a partitioning of variables in the dual Forney factor graph of the 2D Ising model.

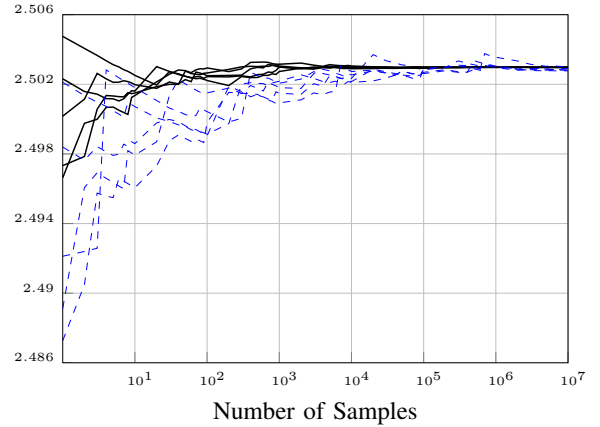

Fig. 5: Estimated log partition function per site vs. the number of samples for a  $30 \times 30$  Ising model, with  $J_k \sim \mathcal{U}[1.0, 1.25]$  for  $k \in \mathcal{B}_A$  and  $J_k \sim \mathcal{U}[1.25, 1.5]$  for  $k \in \mathcal{B}_B$ . The plot shows five different sample paths obtained from importance sampling (solid black lines) and five different sample paths obtained from uniform sampling (dashed blue lines) on the dual factor graph.

### A. 2D Ising models without an external field

We consider a 2D Ising model of size  $N = 30 \times 30$  without an external magnetic field. For  $k \in \mathcal{B}_A$ , we set  $J_k \stackrel{\text{i.i.d.}}{\sim} \mathcal{U}[1.0, 1.25]$  and for  $k \in \mathcal{B}_B$ , set  $J_k \stackrel{\text{i.i.d.}}{\sim} \mathcal{U}[1.25, 1.5]$ .

Fig. 5 shows simulation results obtained from importance sampling (solid lines) and from uniform sampling (dashed lines) in the dual Forney factor graph. From Fig. 5, the estimated log partition function per site is about 2.503.

We observe that importance sampling outperforms uniform sampling (with virtually the same amount of computation time); see also [2], [4].

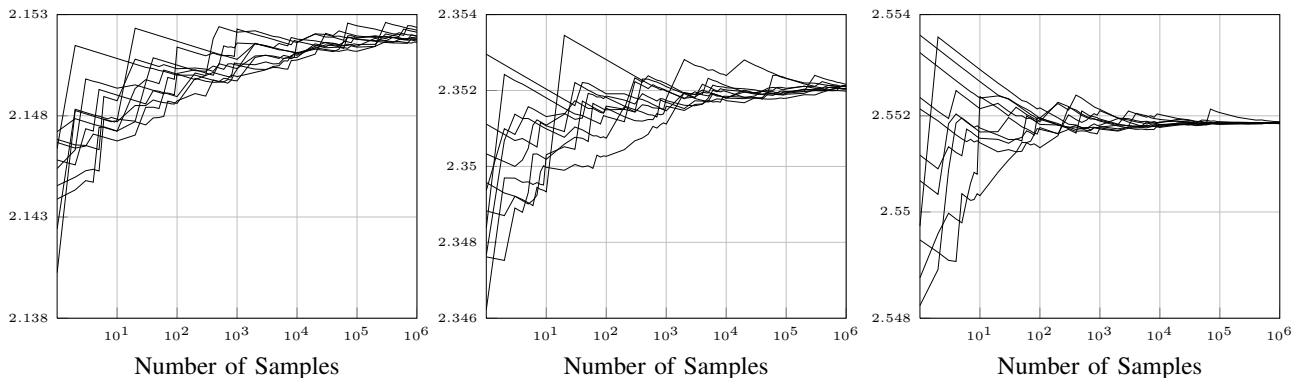

Fig. 6: Estimated log partition function per site vs. the number of samples for a  $50 \times 50$  Ising model, with  $J_k \sim \mathcal{U}[0.1, 1.0]$  for  $k \in \mathcal{B}_A$  and  $H_m \sim \mathcal{U}[-0.8, -0.2]$  for  $1 \leq m \leq N$ ; for  $k \in \mathcal{B}_B$  (left)  $J_k \sim \mathcal{U}[1.0, 1.2]$ , (middle)  $J_k \sim \mathcal{U}[1.2, 1.4]$ , and (right)  $J_k \sim \mathcal{U}[1.4, 1.6]$ . Each plot shows ten different sample paths obtained from importance sampling on the dual factor graph.

### B. 2D Ising models in an external field

We set  $N = 50 \times 50$ ,  $J_k \stackrel{\text{i.i.d.}}{\sim} \mathcal{U}[0.1, 1.0]$  for  $k \in \mathcal{B}_A$ , and  $H_m \stackrel{\text{i.i.d.}}{\sim} \mathcal{U}[-0.8, -0.2]$  for  $1 \leq m \leq N$  in all the experiments.

In the first experiment,  $J_k \stackrel{\text{i.i.d.}}{\sim} \mathcal{U}[1.0, 1.2]$  for  $k \in \mathcal{B}_B$ . Simulation results obtained from importance sampling in the dual factor graph are shown in Fig. 6 (left). In the second experiment,  $J_k \stackrel{\text{i.i.d.}}{\sim} \mathcal{U}[1.4, 1.5]$  for  $k \in \mathcal{B}_B$ . Fig. 6 (middle) shows simulation results. We set  $J_k \stackrel{\text{i.i.d.}}{\sim} \mathcal{U}[1.4, 1.6]$  for  $k \in \mathcal{B}_B$  in the third experiment. Simulation results are shown in Fig. 6 (right), where the estimated  $\frac{1}{N} \ln Z$  is about 2.5518. Notice that in Fig. 6 from left to right, the range of the  $y$ -axis is 0.015, 0.008, and 0.006, respectively.

In agreement with our analysis in Section IV, we observe that convergence improves as  $J_k$  becomes larger for  $k \in \mathcal{B}_B$ .

## VI. CONCLUSION

An importance sampling algorithm was presented for estimating the partition function of the 2D ferromagnetic Ising model in a consistent external magnetic field. The algorithm is described in the dual Forney factor graph representing the model. After introducing a partitioning and an auxiliary importance sampling distribution, the method operates by first simulating a subset of the variables, followed by doing computations over the remaining ones. The algorithm can efficiently estimate the partition function when the model is at low temperature or when the model contains a mixture of strong and weak coupling parameters. The proposed algorithm is applicable to the 3D Ising model and the  $q$ -state Potts model in an external field as well. For duality results in the context of statistical physics, see, e.g., [17], [18], [19, Chapter 10].

### ACKNOWLEDGEMENTS

The author would like to thank Hans-Andrea Loeliger, David Forney, and Justin Dauwels for their helpful comments. The author would also like to thank Pascal Vontobel for proofreading an earlier version of this paper and for pointing out to him [18].

## REFERENCES

- [1] M. Molkaeraie and H.-A. Loeliger, "Partition function of the Ising model via factor graph duality," *Proc. 2013 IEEE Int. Symp. on Inf. Theory*, Istanbul, Turkey, July 7–12, 2013, pp. 2304–2308.
- [2] M. Molkaeraie, "An importance sampling scheme for models in a strong external field," *Proc. 2015 IEEE Int. Symp. on Inf. Theory*, Hong Kong, June 14–19, 2015, pp. 1179–1183.
- [3] A. Al-Bashabsheh and Y. Mao, "On stochastic estimation of the partition function," *Proc. 2014 IEEE Int. Symp. on Inf. Theory*, Honolulu, USA, June 29 – July 4, 2014, pp. 1504–1508.
- [4] M. Molkaeraie, "An importance sampling scheme on dual factor graphs. II. models with strong couplings," [arXiv:1404.5666](https://arxiv.org/abs/1404.5666), 2014.
- [5] K. Binder and D. W. Heermann, *Monte Carlo Simulation in Statistical Physics*. Springer, 2010.
- [6] R. J. Baxter, *Exactly Solved Models in Statistical Mechanics*. Dover Publications, 2007.
- [7] D. E. Knuth, "Two notes on notation," *Amer. Mathematical Monthly*, vol. 99, pp. 403–422, May 1992.
- [8] G. D. Forney, Jr., "Codes on graphs: normal realization," *IEEE Trans. Inf. Theory*, vol. 47, pp. 520–548, Feb. 2001.
- [9] H.-A. Loeliger, "An introduction to factor graphs," *IEEE Signal Proc. Mag.*, vol. 29, pp. 28–41, Jan. 2004.
- [10] J. M. Hammersley and D. C. Handscomb, *Monte Carlo Methods*. Methuen & Co., London, 1964.
- [11] R. M. Neal, *Probabilistic Inference Using Markov Chain Monte Carlo Methods*. Techn. Report CRG-TR-93-1, Dept. Computer Science, Univ. of Toronto, Sept. 1993.
- [12] G. D. Forney, Jr., "Codes on graphs: duality and MacWilliams identities," *IEEE Trans. Inf. Theory*, vol. 57, pp. 1382–1397, Feb. 2011.
- [13] A. Al-Bashabsheh and Y. Mao, "Normal factor graphs and holographic transformations," *IEEE Trans. Inf. Theory*, vol. 57, pp. 752–763, Feb. 2011.
- [14] G. D. Forney, Jr. and P. O. Vontobel, "Partition functions of normal factor graphs," *2011 Information Theory and Applications Workshop*, La Jolla, USA, Feb. 6–11, 2011.
- [15] R. J. McEliece, *The Theory of Information and Coding: A Mathematical Framework for Communication*. Addison-Wesley, 1977.
- [16] R. H. Swendsen and J. S. Wang, "Nonuniversal critical dynamics in Monte Carlo simulations," *Phys. Rev.*, vol. 58, pp. 86–88, Jan. 1987.
- [17] H. A. Kramers and G. H. Wannier, "Statistics of the two-dimensional ferromagnet. Part I," *Phys. Rev.*, vol. 60, pp. 252–262, Aug. 1941.
- [18] R. Savit, "Duality in field theory and statistical systems," *Rev. of Modern Physics*, vol. 52, pp. 453–487, April 1980.
- [19] H. Nishimoro and G. Ortiz, *Elements of Phase Transition and Critical Phenomena*. Oxford University Press, 2011.