

# The City Energy Analyst Toolbox V0.1

**Conference Paper****Author(s):**

Fonseca, Jimeno A.; Thomas, Daren; Willmann, Anja; Elesawy, Amr; Schlueter, Arno

**Publication date:**

2016

**Permanent link:**

<https://doi.org/10.3929/ethz-a-010690828>

**Rights / license:**

[In Copyright - Non-Commercial Use Permitted](#)



## Expanding Boundaries: Systems Thinking for the Built Environment

### THE CITY ENERGY ANALYST TOOLBOX V0.1

Jimeno A. Fonseca<sup>1,2\*</sup>, Daren Thomas<sup>2</sup>, Anja Willmann<sup>2</sup>, Amr Elesawy<sup>2</sup>,  
Arno Schlueter<sup>1,2</sup>

<sup>1</sup>ETH Zurich, Future Cities Laboratory, Singapore-ETH Center. 1 Create Way, 138602, Singapore

<sup>2</sup>ETH Zurich, Architecture and Building Systems. John-Von-Neumann-Weg 9,8093, Zürich

\*Corresponding author; e-mail: [fonseca@arch.ethz.ch](mailto:fonseca@arch.ethz.ch)

#### Abstract

The City Energy Analyst is a novel computational framework for the analysis of building energy systems at neighbourhood and district scales. The framework serves to define strategies that minimize the overall energy intensity, carbon footprint and annualized costs of energy services in urban areas. This paper presents the integration of two modules of this framework into an open-source extension for ArcGIS: The City Energy Analyst Toolbox V0.1. This article discusses an exemplary application of such a toolbox in education. The tool allowed master students in engineering to define the environmental impact of buildings in an urban area and learn about alternatives to ameliorate this. In the future, the tool could support urban designers and energy systems engineers to jointly increase the energy efficiency of urban settlements.

#### Keywords:

Urban energy systems simulation; parametric urban design; IT in education

## 1 INTRODUCTION

The City Energy Analyst (CEA) is a framework for the analysis of building energy systems at neighbourhood and district scales. The framework serves to define energy efficiency strategies that minimize the energy intensity, carbon footprint and annualized costs of energy services in urban areas [1]. The framework has been used in building performance assessments (e.g. [2]), energy systems optimizations (e.g. [1], [3], [4]) and life cycle and resilience assessments (e.g. [5], [6]).

This paper presents the integration of two modules of this framework into an open-source extension for ArcGIS V10.3: The City Energy Analyst Toolbox (CEA Toolbox) V0.1.

Section 2 introduces the components of the framework and the CEA Toolbox. Section 3 introduces an exemplary application in education. Section 4 discusses advantages and constraints of the tool in urban and energy planning practice.

## 2 METHODOLOGY

The CEA Toolbox V0.1 integrates modules one and five of the City Energy Analyst framework (Fig. 1) into the ArcGIS ArcScene software. The first is a building energy demand model. The second is an algorithm for life cycle assessment (LCA) of buildings and infrastructure. Seven databases group all input variables (see Table 1 in the Appendix).

By integrating with ArcGIS, the CEA Toolbox leverages a GIS environment and blends the workflow of the user with the wealth of tools provided by ArcGIS. This facilitates users to link their analysis to other features of the context (e.g. land use, landownership, greenery). For those features, ArcGIS provides a wide set of analysis tools.

The CEA Toolbox wraps the CEA modules into tools defined in an ArcGIS Python toolbox. Each tool provides a dialog for the input parameters and hands these parameters over to the CEA modules for calculation.

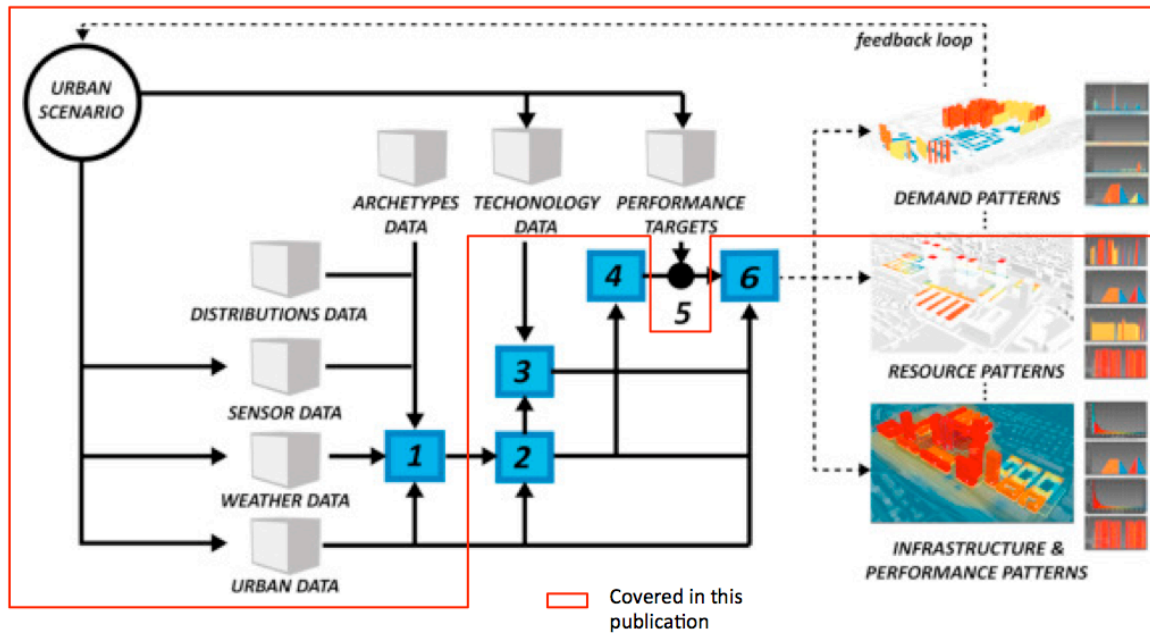

Fig. 1: Overview of the CEA framework: Databases, Modules, and Workflow. 1. Demand module, 2. Resource potential module, 3. Systems technology module, 4. Systems optimization module, 5. Decision module, 6. Spatiotemporal analysis module (extracted from Fonseca et al. [1]).

Fig. 2 shows the various components of the graphical user interface. The Catalog Panel provides access to connected folders, containing GIS data and results from the computations. The Visualization Panel is the main view in ArcScene. It shows the CEA results projected onto the geometry of the urban landscape. The Layer Panel lists the layers displayed in the Visualization Panel. The user can toggle each layer on and off depending on the current visualization needs. The Attributes Panel shows the properties of a layer in a tabular view. The user can use the Attributes Panel to adjust the properties of buildings. The Toolbox Panel contains a list of tools registered with ArcGIS, including the CEA Toolbox.

The tools provided in the CEA Toolbox are Properties, Demand, Embodied Energy, Emissions, and Heatmaps.

The Properties tool initializes the properties of the Buildings layer using the archetypes of [2].

The Demand tool calculates the hourly demand of energy services in buildings according to [2].

The Embodied Energy tool calculates the embodied energy and gray emissions of buildings according to [7].

The Emissions tool calculates the primary energy consumption and greenhouse gas emissions of buildings according to [2].

The Heat-maps tool calculates heat maps from the output of the above tools using the ArcGIS Hot Spot Analysis tool.

The CEA Toolbox is published under the open source MIT License [8] on GitHub [9].

### 3 RESULTS

Eight master students in Integrated Building Systems evaluated a potential energy system for the “Hochschulquartier” in Zurich for 2030. The energy system had to achieve the benchmarks of the 2000-Watt Society [10]. This academic exercise had three phases (Fig. 3):

#### Phase I: Status Quo Analysis

This phase defines the boundary conditions for potential retrofits to infrastructure and buildings. It consists of data collection, simulation of the existing setting and potential analysis. The data collection task gathers the parameters of Table 1 from official documents, maps, questionnaires and on-site surveys. The CEA Toolbox is used to compute the carbon footprint and energy intensity of the area (Fig. 3a), and to identify low-performing buildings (Fig. 3b).

The potential analysis (Fig. 3c) uncovers opportunities (e.g., distributed generation and building retrofit opportunities) and constraints (e.g. building preservation) to increase the energy efficiency of the area.

#### Phase II: Scenarios development

This phase comprises the development of urban design scenarios. Each scenario is described by modifications to the variables of Table 1.

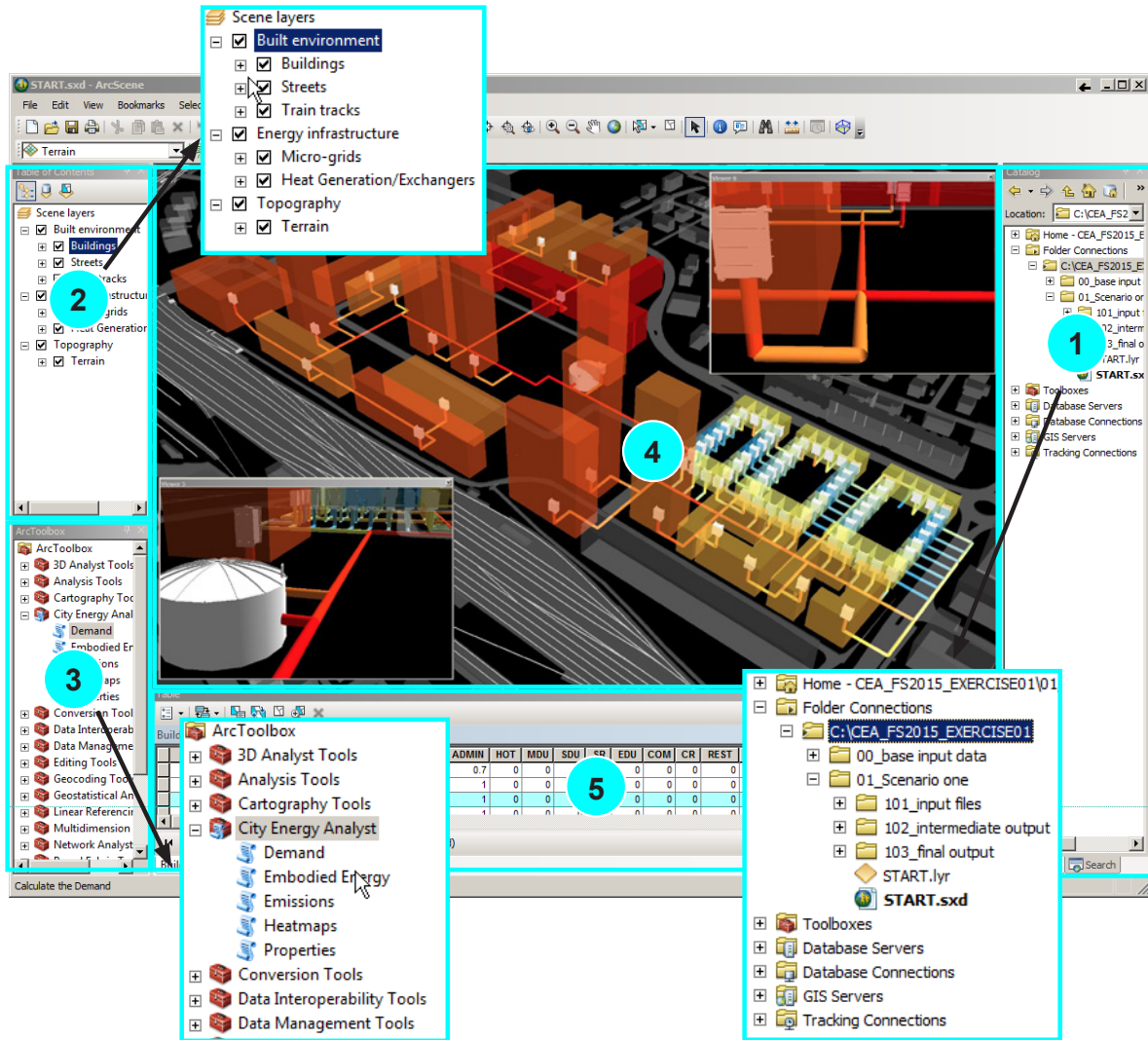

Fig. 2: Graphical user interface, 1. Catalog Panel, 2. Layer Panel, 3. Toolbox Panel, 4. Visualization Panel, 5. Attributes Panel.

The CEA Toolbox is used to calculate the energy demand of the scenarios. The results are then evaluated against the opportunities to increase the efficiency of the area (Phase I). A comparison phase follows, which determines the most fitting strategy for the intervention. This strategy needs to comply with the carbon and energy limits of the 2000-Watt Society [10]. This phase determines the need for a new iteration. Fig. 3d presents an example of this process.

### Phase III: Energy Systems Proposal

After evaluation, the energy system of the area is depicted in three diagrams: an urban energy systems diagram (Fig. 3e), a 3D map (Fig. 3f), and a Sankey diagram (Fig. 3g). The urban energy systems diagram describes the components and interconnectivity rules of the system. The Sankey diagram describes the yearly balance of energy flows per end-use. The map describes the location of every infrastructure component.

## 4 DISCUSSION AND CONCLUSIONS

The CEA Toolbox allows users to estimate the performance of an urban energy system. Moreover, it helps users to identify the spatial relation between urban design and energy systems decisions. From the teaching perspective, the use of such a low-barrier tool facilitates an intuitive access to urban energy interactions for entry-level experts.

The first version (V0.1) of the CEA Toolbox presents a series of limitations in terms of model accuracy, user experience and concept of operations.

Based on data of [1] and [2], the demand module of the CEA Toolbox has a mean error of 32% at the building scale and 5% at neighborhood scale ( $n=24$ ). Future work to decrease this error might lie on calibration with sensor data and implementation of more advanced models for air ventilation and occupancy.



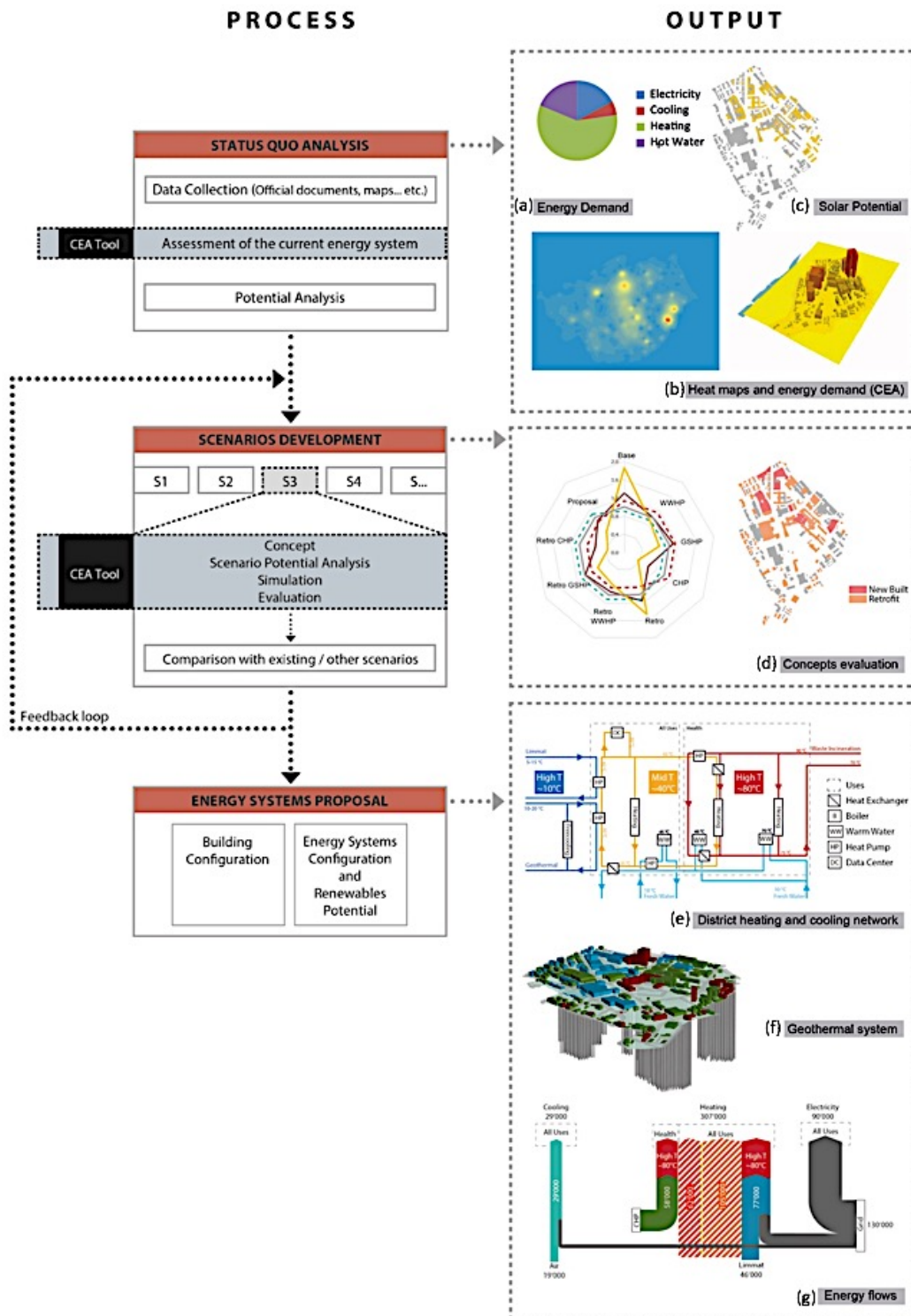

Fig. 3: Process overview and output examples.

The CEA toolbox V0.1 provides a limited analysis of alternatives for energy generation. It does not consider the economics and technical restrictions of infrastructure during design and operation. The future implementation of the remaining models of the CEA framework should address this limitation.

The toolbox presents low levels of automation about reporting and generation of multiple

scenarios. A cloud-based architecture would facilitate the real-time evaluation of scenarios. Such a feature has been one of the key advantages of other low-barrier tools in sustainable architecture (e.g. [11], [12]). Future tests with urban designers and energy systems engineers would help to identify other features that improve user experience.

Practitioners could find the CEA Toolbox useful to forecast the performance of an urban energy system and link the results to other features of the context in a GIS interface. A new concept of operations could allow users to integrate urban design and energy systems planning in their current practices. This aspect could require professionals with knowledge in both areas.

## 5 ACKNOWLEDGMENTS

The authors thank Moritz Begle for his teaching support. Thanks are also due to students of the Master's program in Integrated Building Systems (MBS) at ETH Zurich, who attended the course on integrated design in the fall semester of 2015: Julia Breu, Stefan Caranovic, Marc Lallemand, Jonas Landolt, Randi Nanayakkara, Paul Neitzel, Yasmine Priore and Yueqiu Wang.

## 6 REFERENCES

1. J. A. Fonseca, T.-A. Nguyen, A. Schlueter, and F. Marechal, "City Energy Analyst (CEA): Integrated framework for analysis and optimization of building energy systems in neighborhoods and city districts," *Energy Build.*, vol. 113, pp. 202–226, Feb. 2016.
2. J. A. Fonseca and A. Schlueter, "Integrated model for characterization of spatiotemporal building energy consumption patterns in neighborhoods and city districts," *Appl. Energy*, vol. 142, pp. 247–265, 2015.
3. T. Vollrath, "Local micro-grids for low-carbon building systems," ETH Zurich, 2015.
4. T.-A. Nguyen, "Optimization of a District Energy System in the context of Urban Transformation," ETH Zurich, 2015.
5. J. A. Fonseca, A. Willmann, C. Moser, M. Stauffacher, and A. Schlueter, "Assessing the environmental impact of future urban developments at neighborhood scale," in *Proceedings of CISBAT 2015*, 2015, p. 6.
6. J. A. Fonseca and A. Schlueter, "Assessing the performance and resilience of future development at neighborhood scale," in *SBE 2016, Expanding Boundaries: Systems Thinking for the Built Environment*, 2016, p. 5.
7. E. Thoma, J. A. Fonseca, and A. Schlueter, "Estimation of base-values for Grey Energy, Primary Energy, Global Warming Potential (GWP 100A) and Umweltbelastungspunkte (UBP 2006) for Swiss constructions from before 1920 until today," in *Contemporary Urban Issues '14*, 2014, no. Ubp, p. 17.
8. Open Source Initiative, "MIT License," *Software Licenses*, 2016. [Online]. Available: <https://opensource.org/licenses/MIT>. [Accessed: 26-Jan-2016].
9. Architecture and Building Systems, Institute of Technology in Architecture, and ETH Zurich, "The CEA Toolbox V0.1," *Repository*, 2016. [Online]. Available: <https://github.com/architecture-building-systems/CEAforArcGIS>.
10. D. Kellenberger, M. Ménard, S. Schneider, M. Hänger, M. Org, K. Victor, and S. Lenel, *Arealentwicklung für die 2000-Watt-Gesellschaft: Beurteilungsmethode in Anlehnung an den SIA-Effizienzpfad Energie*. Bern: Bundesamt für Energie, 2012.
11. Sefaira Ltd., "Sefaira Architecture." Sefaira, London, GB, p. 1, 2015.
12. A. Schlueter and F. Thesseling, "Building information model based energy/exergy performance assessment in early design stages," *Autom. Constr.*, vol. 18, no. 2, pp. 153–163, Mar. 2009.

## 7 APPENDIX

Database	Variable	Format	Variable	Format
Weather data	Ambient temperature Relative Humidity	.csv .csv	Solar transmissivity.	csv
Urban data	Buildings: Footprint area Roof inclination Height Window-to-wall-ratio Shading system HVAC system Generation technology type Occupancy type Construction year Renovation year	.shp .shp .shp .shp .shp .shp .shp .shp .shp .shp	Environment: Streets layout* Sewer layout* Power network layout 3D Topography Water body layout* Soil strata*	.shp .shp .shp .tiff .shp .shp
Archetypes data	HVAC: Type Operating temperatures	.csv .csv	Envelope: Thermal mass type Thermal transmittance	.csv .csv
Distribution data	Occupancy: Schedules Minimum ventilation rates Temperature set-point	.csv .csv .csv	Humidity set-point Fresh water requirements Hot water requirements	.csv .csv .csv
Sensor database	Measured variables in any other database.*	.csv or .shp	Context specific hourly end-use demands (e.g. industrial processes)*	.csv
Technology database	Primary energy factors. CO <sub>2</sub> -eq factors.	.shp .shp	Costs.*	.csv
Performance targets data	Grey emissions per building component area.* Embodied energy per building component area.*	.xls .xls	Local standard Minergie* 2000-watt society standard	.xls

Table 1: Databases and variables of the CEA framework. \*variables not integrated into the CEA Toolbox V0.1.