



# The Potential of Reverse Engineering and Digital Fabrication for the Repair of High-Tech Architecture

**Conference Paper****Author(s):**

[Brenner, Matthias](#) ; [Vandenabeele, Louis](#); [Langenberg, Silke](#) 

**Publication date:**

2023

**Permanent link:**

<https://doi.org/10.3929/ethz-b-000623396>

**Rights / license:**

[Creative Commons Attribution 4.0 International](#)

**Originally published in:**

International Archives of the Photogrammetry, Remote Sensing and Spatial Information Sciences XLVIII-M-2-2023, <https://doi.org/10.5194/isprs-archives-XLVIII-M-2-2023-303-2023>

## THE POTENTIAL OF REVERSE ENGINEERING AND DIGITAL FABRICATION FOR THE REPAIR OF HIGH-TECH ARCHITECTURE

M. Brenner\*<sup>1</sup>, L. Vandenabeele<sup>2</sup>, S. Langenberg<sup>1</sup>

<sup>1</sup> ETH Zurich, Department of Architecture, Professorship for Construction Heritage and Preservation – (brenner, langenberg@arch.ethz.ch)

<sup>2</sup> ETH Zurich, Department of Architecture, Chair of Building Archaeology and Construction History – vandenabeele@arch.ethz.ch

**KEYWORDS:** Repair, Photogrammetry, Digital Fabrication, Reverse Engineering, High-Tech Architecture, Heritage Conservation, Additive Manufacturing, Resource Efficiency.

### ABSTRACT:

Novel façade constructions and innovative load-bearing structures of the second half of the 20<sup>th</sup> century pose new challenges for maintenance and repair. The use of advanced technology, especially in High-Tech architecture, calls for the development of specific repair methods adapted to specific building materials and construction techniques. The conservation of these aging facades, often composed of custom-made metal components, requires the production of intricate spare parts to avoid unduly replacements. Digital fabrication presents a possible solution as it allows for the resource-efficient production of complex and non-planar geometries in small numbers while remaining cost-effective. The paper explores the use of photogrammetry and laser scanning to reverse engineer spare parts, as original plans are often missing or incomplete. A complete workflow for the fabrication of bespoke metal components is described using two examples of Swiss High-Tech architecture featuring challenging structural nodes and planar aluminum panels. Finally, the feasibility of remanufacturing spare parts is demonstrated with 3d-printed models.

### 1. CHALLENGES AND OPPORTUNITIES FOR REPAIRING INNOVATIVE CONSTRUCTIONS

Constructions of the second half of the 20<sup>th</sup> century pose challenges for their conservation due to “new and experimentally used materials or construction methods” and the “lack of specific professional experience with their repair” (ICOMOS, 2011). ICOMOS, the International Council on Monuments and Sites, focuses in article 3 of the 2011 Madrid Document, on the technical characteristics of the architectural heritage of this period and stresses the need for specific repair methods for more recent building materials and construction techniques.<sup>1</sup> This assessment applies in particular to the “High-Tech Architecture” from the 1980s with its innovative façade and load-bearing structures whose design concepts are based on using and displaying advanced technology (Buchanan, 1983). These buildings, considered – and remaining – technically sophisticated, start to be due for renovations in the areas of façade and building services, which will require an expansion of the repertoire of tools for repairing them. Here, a collaboration between civil as well as mechanical engineers, architects, and preservation specialists is necessary. Indeed, the fact that aircraft and ship components have significantly influenced the design and construction enlarges the scope of the expertise required. Still today, technical know-how in aircraft engineering to produce high-performance components can be beneficial to “high-tech” buildings when they are being repaired.<sup>2</sup>

In the 1980s, custom-made metal components started to be produced on limited series for the construction of complex façade details. In principle, the manual reproduction and replacement of these industrially manufactured components would be possible (e.g., with machine tool). However, this approach would only imitate the original manufacturing principle and not be *process-conform* with the industrial production of limited series some 50 years ago. In practice, reproducing only a few customized replacement parts of a larger series would be financially unacceptable. As only large-scale interventions would justify the costs, a total replacement of components is often conducted, even if this is ecologically more than questionable with regard to our limited resources. As such, for the long-term conservation of these buildings, it consequently stands to reason to use again the latest technologies of our time – currently digital fabrication – in accordance with the innovative spirit of the buildings. This has the potential to reduce the replacement of components through targeted reproduction where replacement becomes necessary. Furthermore, it allows a more resource-efficient bespoke production of the necessary components.<sup>3</sup> Hence, using digital fabrication to repair High-Tech architecture complies with conservation

---

manufacturing (e.g., CATIA) for architectural design. “The generative and creative potential of digital media, together with manufacturing advances already attained in automotive and airplane industries, is opening up new dimensions in architectural design.” (Kolarevic 2001) Currently, the facilitation of knowledge transfer between the disciplines is relevant for *the repair of architecture*.

<sup>3</sup> This topic is further discussed in the upcoming article by Matthias Brenner and Silke Langenberg “High-Tech Architektur: Herausforderungen und Möglichkeiten der Erhaltung”, published in the conference proceedings of “Denkmal Postmoderne. Erhaltung einer ‘nicht-abzuschliessenden’ Epoche” in German.

---

\* Corresponding Author

<sup>1</sup> The potential of digital fabrication for the repair of innovative constructions of the 1980s is being investigated in the ongoing dissertation project of Matthias Brenner under the supervision of Prof. Dr. Silke Langenberg at ETH Zurich.

<sup>2</sup> This discussion was already relevant for architecture around the turn of the millennium: Architects explored using 3d modelling tools already established for industrial design and

principles such as targeted minimal intervention, identification of repairs on close inspection, and retaining meaning. Fundamentally, this type of repair intervention can only be carried out with the help of a precise 3d model of the actual geometry of the building component in question. Digital plans are generally not existing and, in many cases, also the original construction documents are either lost or what remains is not detailed enough to form a base for a digital reproduction. Also, the companies which manufactured these parts usually either no longer exist or do no longer produce them. Therefore, the building components found on site are the primary source for the reverse engineering process of spare parts. Of course, this documentation process needs to be supplemented by archival research. Precise construction models can be produced leveraging surveying techniques such as photogrammetry and laser scanning. The combination of *reverse engineering* and *digital fabrication* technologies unfolds their full potential to deliver innovative repair strategies for complex building elements. This contribution discusses a novel intervention strategy based on a collaborative research project between the Chair for Construction Heritage and Preservation, the Chair for Building Archaeology and Construction History, and the Chair for Advanced Manufacturing, at ETH Zurich. The paper provides a complete workflow necessary for the repair of complex bespoke metal components on two examples of Swiss High-Tech Architecture: the university building "CLA" of ETH Zurich (1990s) and the Zurich distribution center of the Swiss Post "Briefzentrum Mülligen" (1980s).

## 2. THE COMPLEX NODE GEOMETRY OF THE BUILDING "CLA" OF ETH ZURICH

The university building "CLA" at Clausiusstrasse in Zurich provides laboratory and office spaces for the Department of Mechanical and Process Engineering and is part of the central campus of ETH Zurich. It was designed in 1986 by Fosco Fosco-Oppenheim Vogt architects and was built in two stages between 1990-98. (Fig. 1)

A central hallway separates the floor plan of the longitudinal building into two main parts: The laboratories are tucked away on the northeast side along Clausiusstrasse, while the office spaces are located along the southwest side overlooking the city of Zurich. This longitudinal division is also articulated in the stark contrast of the façade design: On one side, large window openings allow for views over the city and provide generously light-flooded office spaces. While the ventilated façade of the laboratories on the northeast side features comparably small rectangular openings and is constructed from dark horizontally folded metal slats. This division was an active design decision by the architects to reduce the cooling load of the laboratory spaces<sup>4</sup> (Hanak 2005). Due to the large openings in the façade of the office spaces, a filigree brise soleil was installed on the southwest side. This expressive sun protection element prevents direct sunlight from entering but brightens up the interior when the sky is overcast so that diffuse lighting is always insured. At

first glance, it gives the impression of being movable but is in reality a rigidly mounted structure. The planar components of the construction are made of two layers of laminated safety glass, between which there is a white PVB film. They are anchored by green thermo-lacquered steel saddles and vertical stainless steel support tubes.

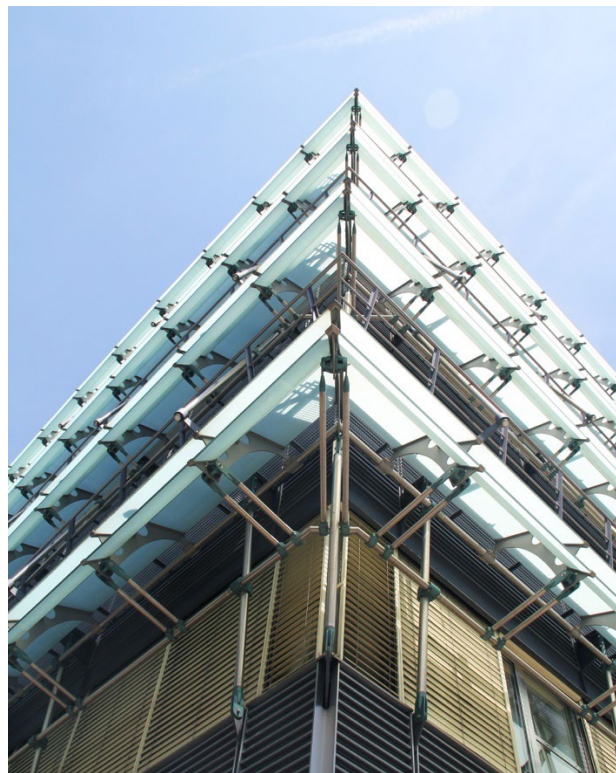
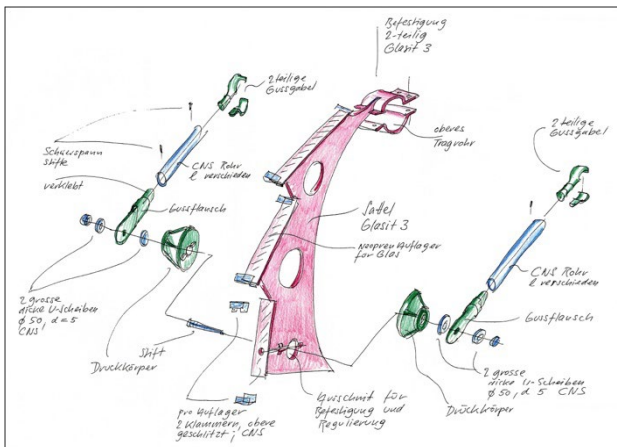

Figure 1. View of the "CLA" façade from Tannenstrasse

These joints consist of custom-made components manufactured solely for this part of the façade construction and form the first case study in a repair scenario of a complex façade component. In this scenario, we investigated how a repair using digital fabrication could be implemented in case of a defect on one of the custom-made nodes, using metal 3d printing of a spare part. As is often the case for innovative buildings of the 1970s-90s, detailed construction drawings are lost. In the case of the "CLA", the most detailed construction drawings went missing when the Swiss specialist metal construction company "Soder", which produced the façade elements for CLA, was liquidated in 2007. The remaining documents kindly provided by the architects at the beginning of the research (Fig. 2) reveal the carefully thought-out construction principle of the façade but were not detailed enough to develop a 3d model for fabrication. In the absence of original plans<sup>5</sup>, the decision was made to use photogrammetry to reverse engineer a precise 3d model based on the existing façade element (marked as "Gussflansch" on the bottom right in Figure 2) which would stand to benefit from metal 3d printing of a spare part.

<sup>4</sup> In the delicate technical façade, art historian Michael Hanak sees a relationship between the design and use of the building: "The curtain construction for the Brise-Soleil is reminiscent of a massive machine, in keeping with the fields of study represented behind it." (Hanak 2005) With this, he seems to refer to a statement made by the architect Benno Fosco himself, who mentioned in a 1999 interview that the "technical expression of the façade [...] also corresponds to the highly technological research activities inside the institute building." (Schär and Fosco 1999)

<sup>5</sup> Post-completion, 2D drawings of construction details have fortunately come to light. These plans have proven to be very helpful in the current phase of the project, as they facilitate verification of the reconstructed 3d model. Nevertheless, for the precise modelling of especially non-planar surfaces in the 3d model, reliance on the 2d construction drawings alone would not have sufficed. Additionally, the drafted construction drawings don't necessarily represent the executed geometry on site.



**Figure 2.** Construction sketch of the “CLA” façade by Fosco Fosco-Oppenheim Vogt Architects

The reconstruction of the geometry found on site was conducted in two steps<sup>6</sup>: Firstly, photogrammetry was used to capture the geometry of the specific façade element. The resulting point cloud was used in a second step as a basis for a new 3d model for fabrication.

### 2.1 Challenges encountered with photogrammetry

Deploying photogrammetry offered the opportunity for a non-invasive analysis of the geometry on site. Potentially, the resulting point cloud could have been more precise if the component would have been analyzed under laboratory conditions and not in situ. But this was not a valid approach for reasons of building conservation since the disassembly of a fully functional building component would have posed not only a significant risk of damage to the original substance of the metal node itself but also its surrounding components. Since the investigated façade component is located outside the building envelope and is more than 15 meters over the ground level, the deployment of a drone was discussed for photogrammetry. Unfortunately, the “CLA” is located in a strict no-fly zone surrounding the helipad of the Zurich University Hospital. Therefore, approximately 900 pictures were taken manually with a handheld digital camera while secured by special climbing gear on mobile scaffolding on the southwestern façade. The first results were of mixed quality. Two challenges intrinsic to the object of investigation became apparent: the repetition of form and the surface material. The multi-part construction of the brise-soleil is organized in vertical bays which are composed of several custom-made metal components (depicted in green and red in Figure 2). The investigated bay design is frequently repeated along the southwestern façade. This local geometric repetition of bespoke elements proved to be a source of error when calculating the point cloud. An adjustment had to be made to enable the software (Agisoft Metashape) to uniquely identify the analyzed component. This was done by carefully selecting the point of view for the camera to not include any building component from a neighboring bay. A further substantial improvement was made by temporarily attaching uniquely marked dots on the surface of the façade element. These markers allowed the photogrammetry software to better identify and match key points on the surfaces of the

<sup>6</sup> This work was conducted in close collaboration with Clement Estreicher, as part of his focus work at the Chair for Construction Heritage and Preservation supervised by Matthias Brenner.

component. The surface materials of the brise soleil themselves posed a challenge when photographing the green metal nodes: The planar sheets of laminated safety glass in combination with the white PVB film intensely diffused the light when photographing the green metal nodes underneath, overexposing the shots. Photographing the structure when the sky was overcast and the sun was almost set, improved the outcome greatly. Additionally, the surface of the green metal nodes and the attached stainless-steel tubes themselves were posing another challenge since they are prone to glare and reflection. After discussing possible solutions based on temporary powder applications with the Facility Management of the “CLA”, an extraordinary weather condition changed the conditions on site: Sahara dust fell over Zurich in March of 2022, applying an even coating of fine orange dust on the normally highly reflective metal structure of the “CLA” façade. For a short period of time the surfaces were almost completely free of glare and their geometry could be retrieved utilizing photogrammetry.

### 2.2 From point cloud to mesh model

The resulting point cloud proved to be a solid base for the second step in the reverse-engineering process of the spare part: It served as the base for building a precise 3d model for fabrication that was constructed leveraging 3d modeling tools. Starting from the point cloud as a base for a 3d fabrication model for 3d printing, two different strategies were tested. Firstly, a mesh model was calculated directly from the point cloud in the photogrammetry model. At first sight, the mesh model seemed precise enough for fabrication. Since metal 3d printing is associated with comparatively high material and energy costs, a first test was printed on the scale of 1:1 with a nylon 3d printer in collaboration with the Chair for Digital Building Technologies (Prof. Dr. Benjamin Dillenburger) at ETH Zurich. (Fig. 3)



**Figure 3.** Test print in scale 1:1 of the mesh model

Especially on the top right part of the test print the surface geometry of the mesh model directly retrieved from the point cloud was partly imperfect. The result showed that the point cloud is not precise enough for digital fabrication with metal. The main source of errors regarding the geometry of the mesh model is the noise of the point cloud resulting from the remaining reflectivity of the objects. A few single points are offset by a small distance from the main surface which makes for parts of the geometry to stick out or be pushed in when meshed. These surface imperfections become especially notable on flat or cylindrical surfaces, less so on non-planar ones. As shown by Lanzara et al. (2022), point cloud filtering and mesh editing hardly improve these imperfections for reflective surfaces.



### 2.3 Reverse engineering

Subsequently, the decision was made to use the point cloud as a starting point for a new 3d model using reverse engineering. The point cloud was imported into a 3d modeling software (Rhinoceros 3D) and scaled according to measurements taken on-site. Then, a series of design parameters were extracted to guide the reconstruction of fitted geometries. To do so, an array of parallel section planes was intersected with the point cloud, perpendicular to its main axes depending on the subpart of the component and its main geometric orientation (e.g., plane vs. cylinder). (Fig. 4)

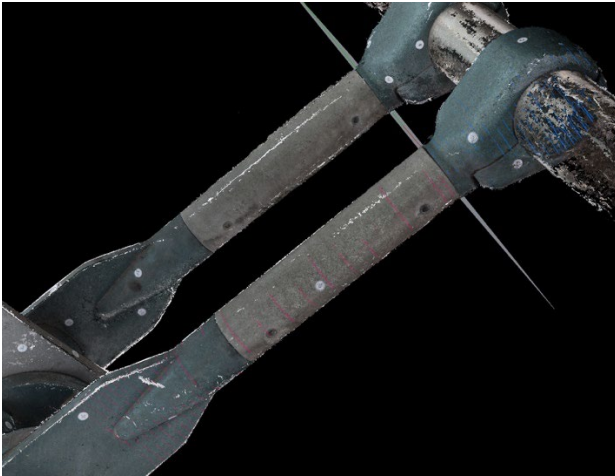

Figure 4. Section curves on the point cloud model

The model was split into two subgroups of components divided by the stainless-steel tube which was not necessary to reverse engineer since it can be measured and modeled easily by hand or using a standard tube element available in many software programs. Additionally, this component would not be metal 3d printed but acquired conventionally from suppliers since it is not bespoke but a mass-produced common building part. To filter out the few points that were incorrectly placed by the photogrammetry software, best-fitting geometries were applied (e.g., "line through points", "circle: fit points" or "fit plane through points") to the elements with non-linear complex surfaces. This approximation between section curves allowed for the overall geometry to be modeled with much smoother poly-surfaces (Fig. 5), compared to the imperfections of the mesh model retrieved directly from the point cloud.

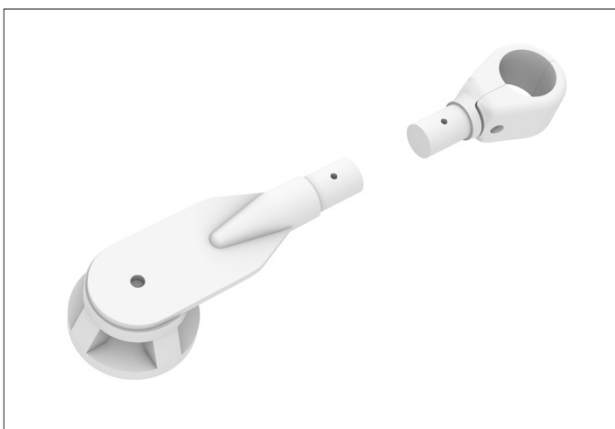

Figure 5. Reverse-engineered 3d model of the façade elements

The resulting model is a suitable representation of the geometry for digital fabrication because of its simplicity and the absence of surface irregularities. Not all information can be taken from the 3d model which solely displays the outer surface geometry. Important information for the fabrication of the component, e.g., the thickness, internal joints, or hollowness, is not possible to retrieve from the model alone. Thus, comprehensive knowledge of construction principles as well as detailed on-site inspection are needed for an accurate assessment. Additionally, certain assumptions must be made if the scenario demands an intervention without disassembly and invasive examination of the original substance.

Currently, a spare part is being produced in collaboration with the Chair for Advanced Manufacturing (Prof. Dr. Markus Bambach) at ETH Zurich. Wire Arc Additive Manufacturing (WAAM) and laser metal deposition are two promising technologies for this application.

### 2.4 Review of the photogrammetry workflow

Photogrammetry served as a highly useful tool by enabling the complete workflow laid out from the on-site geometry of the original building component to the 3d model for production and the digital fabrication of a spare part. It allows for the reverse engineering of a spare part utilizing a digital model based solely on photogrammetry, without detailed construction documents or other supplementary archival documents. (Fig. 6)

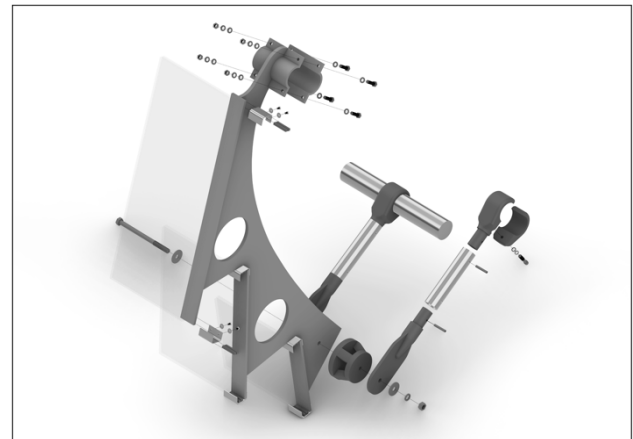

Figure 6. Axonometric view of the "CLA" façade model

One of the main challenges encountered in this workflow is the conversion from a point cloud to a suitable 3d model that can later be used for fabrication. Since even comparably few imperfections in the 3d model are materialized directly in the digitally fabricated component, the intermediate step of re-modeling the geometry based on information retrieved from the point cloud was necessary. Further improvements to this initial workflow could allow for a significant reduction of time spent on remodeling. On the other hand, re-modeling is worth the effort since the 3d model for production needs to be only created once. If stored correctly it can be used to produce spare parts in the future on demand. The production can commence as soon as a spare part is needed. In the special case of the "CLA", the metal 3d printing happens in the underground laboratories of the very same building – the spare parts are thus manufactured in-house. Considering a case where not all parts are identical and undeformed, a workflow can be employed wherein a 3d scan of the initial element is converted into a parametric model including a set of best-fitting geometries. This model can then be used for the 3d printing of a spare part. For subsequent

repairs, a new 3d scan can be efficiently executed, and the resulting geometry quickly refit using the existing parametric model. This enables the fabrication of a new spare part that adheres to the same design principles, albeit with slight modifications. The defect of a complex metal façade element can be remedied by a targeted replacement with a spare part, to keep as much of the original substance of the overall façade construction in place. This method offers more resource-efficient repair interventions while conserving as much of the original façade by keeping it in place. Further investigations need to be conducted regarding the sustainability of the additive metal manufacturing process in comparison to subtractive metal machining applications.<sup>7</sup> Different digital fabrication strategies must be applied depending on the façade geometry and the original fabrication rationale of the defective element: Several Swiss High-Tech buildings feature planar steel and aluminum façade constructions. These follow a different production rationale, which is illustrated by the following case study of the distribution center "Briefzentrum Mülligen" of the Swiss Post.

### 3. PLANAR SHEET METAL ELEMENTS OF THE "BRIEFZENTRUM" FACADE

The "Briefzentrum" serves the Swiss Post as a distribution center and is situated in a residential area in Mülligen, just outside the city of Zurich. Theo Hotz Architekten won a competition in 1970 to design the new postal distribution center to augment the facilities of the Swiss Post around Zurich in response to the increasing volume of shipments. (Hotz 1987) A suitable site for the new distribution center was found next to the SBB rail bed in Schlieren. (Vögtlin 1986a) At the time, letter mail was rail-bound making the connection to the SBB rail network an important consideration in the site selection process. After undergoing a process of design adjustments, the building was realized between 1981 and 1985. With its enormous size of approximately 250 by 140 meters, it contrasts the small-scale solitary plot structure of the residential zone on the opposite side of the Zürcherstrasse. Its volume is articulated in two main building parts: one 26-meter-high operation facility which mainly houses the sorting and distribution machinery and short-time storage facilities, and a 48-meter-high service tower. The footprint of the latter is shaped like a quarter of an octagon that features slanted facades towards the outside, with cranes on the very top. It provides spaces for central functions of control, infrastructure, and contact with the public. Since the building is mostly operated around the clock, the decision was made to also allocate accommodations for employees, structured as 6 duplex apartments. The façade is almost entirely covered with aluminum panels that were stamped, bent, and deep-drawn. To increase their strength and stiffness, the geometry of the sheet metal features characteristic horizontal profiles with rounded edges (German: "Sicken"), a characteristic which also further articulates the enormous façade. The building's exterior presents a silver-grey building envelope consisting of vertically overlapping curtain-type elements, executed as a sandwich construction. The powder-coated aluminum façade panels are 3-millimeter thick and mounted on a grid of 2.25 meters. They are held in place by a self-supporting steel sheet shell that is 5-millimeter thick and located on the inner side of the panels. Between the two sheet metal layers, an insulation layer is installed. (Hotz 1987) The façade design is characterized by several instances of soft-edge aesthetic. This characteristic is evident not only in the façade openings, such as the large

vertical windows but also in several doors that feature rounded edges. Moreover, the exterior edges of the building itself are shaped as rounded edges on several occasions, further contributing to the soft-edge aesthetic.

The massing as well as the distinct design of the façade evoke the image of an aircraft carrier. Aluisse served as a supplier providing roughly 400 tons of Peraluman 151 (AlMg1.5) sheet in a thickness of 3 millimeters for the large surface exterior skin elements. Once formed, the elements were coated with a natural-color enamel finish. (Vögtlin 1986b) The envelope construction was realized in collaboration with Geilinger AG overseeing the overall façade construction and producing the structural folded steel shield on the inside.

#### 3.1 Surveying with laser scanning and drone photogrammetry

Like on cars, aluminum façade panels of High-Tech buildings are often the first elements that require a replacement due to their sensitivity to impacts and scratches. In current façade maintenance operations, damaged elements are usually inspected, measured, dismantled, and replaced with the assistance of industrial rope access professionals. In the case of the Briefzentrum, the possibility to reproduce and replace some of the many panels that compose the outer skin of this immense building (250x130 m) using advanced surveying techniques was investigated. As its grey façades are high (between 26 and 40 meters), smooth, and not always vertical, a first challenge was to survey them accurately and safely with minimum interventions (i.e., no scaffolding, rope climbing, or dismantling of panels). Therefore, a section of the Southern facade was surveyed with a high-precision laser scanner (Leica RTC 360) and a 4K drone (DJI Mini 3 Pro with a 12 megapixel camera), offering the basis for a detailed comparison of the two approaches. As in the previous example, the lighting conditions were ideal for structure from motion (SfM) as the sky remained overcast during the entire survey. The laser scan provided a very accurate survey of the lower panels of the façade, which is in the optimal range of precision (1.9 mm at 10 m and 2.9 mm at 20 m, according to the manufacturer). (Fig. 7)

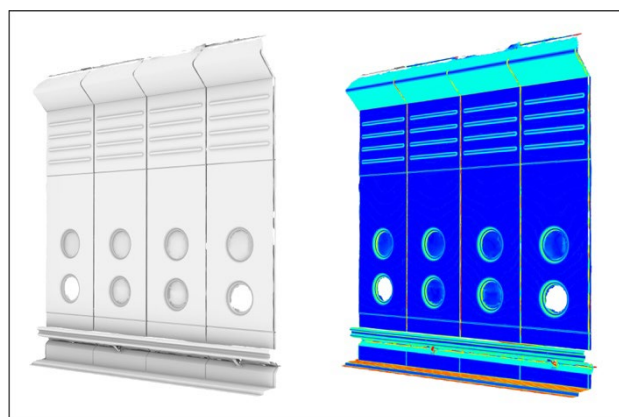
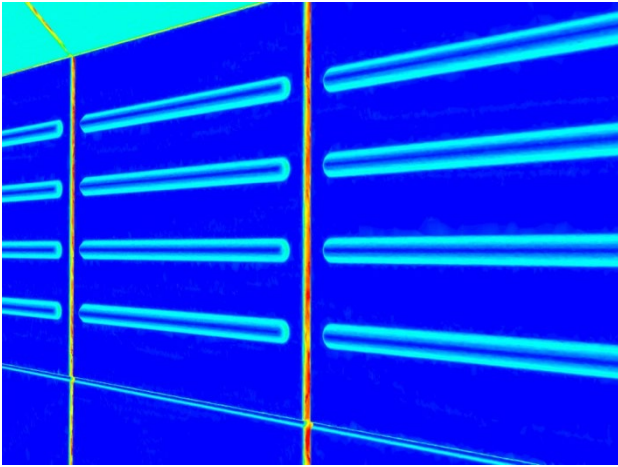

Figure 7. Mesh of the lower panels obtained from a ground-based laser scan. Left: render, right: draft angle analysis

With only 4 setup positions on the ground, the subtle geometry of the panels is accurately captured. (Fig. 8) Moreover, the smoothness of the surfaces does not pose any issue for cloud-to-cloud registration (overall error of 2 mm) because distinguishable features like the thin joints can be used in the process. However, the limits of this ground-based approach become apparent in the upper parts of the façade.

<sup>7</sup> Here fore, Prof. Julian Allwood's research at the University of Cambridge offers promising insights.



**Figure 8.** Detail of the mesh obtained with a laser scan, capturing accurately the panels' geometry (draft angle analysis)

Firstly, the point cloud is less dense and accurate (precision of 5.3 mm at 40 m). Secondly, many surfaces are simply not visible from the ground, not to mention the hidden rain gutter and the roof edge. A drone survey aimed at remedying these shortcomings provided mixed results despite the ideal surveying conditions and high overlap of 261 images. On the one hand, the joints and the surfaces that do not consist of uniformly grey panels were reconstructed with great accuracy in the software Agisoft Metashape. As regards the aluminum panels, those inclined were successfully captured due to a more advanced stage of weathering, making the surfaces less uniform and providing more identifiable details for SfM. (Fig. 9)



**Figure 9.** Detail of the upper part of the drone survey, showing varying results depending on the surface type and weathering

On the other hand, the smooth surfaces of the vertical panels are simply missing in the survey. Indeed, their perfectly even surface is inherently incompatible with SfM, which relies on feature detection and matching for 3d reconstruction. Overall, the alignment of the images was only achieved owing to the GPS coordinates of the drone stored in the metadata of each image. The central part of the façade was particularly challenging due to the presence of large windows in reflective coated glass. Despite GPS data and the systematic application of masks on windows in the SfM software to exclude reflected features, very few pictures aligned successfully on this section of the façade. Further attempts in the software Reality Capture did not provide better outcomes. In further experiments, the

challenge of applying SfM to uniform surfaces could be tackled in different ways. First, on close inspection, there is always some level of dust or weathering – even on vertical panels – that could be recorded with a camera of much higher resolution and used for feature detection in a SfM software. Also, improving significantly the precision of the camera positions with an RTK drone (about 1 cm vs. 1 m with other drones) could greatly facilitate the alignment of pictures where few features are detected. Finally, one could also consider the application – possibly with drones – of washable spays or temporary markers on the surveyed surfaces to increase the number of usable details in SfM.

### 3.2 Combining laser scanner and drones

Although both methods have their own limitations, combining them provides a convincing result. Indeed, the non-vertical surfaces poorly or not covered by the laser scanner are exactly those best surveyed with the drone. Despite significant gaps in each separate survey, their overlap is sufficient to finely align the two point clouds using Cloud Compare. The result is a dense point cloud of the façade from which each single aluminum panel can be measured accurately. (Fig. 10)

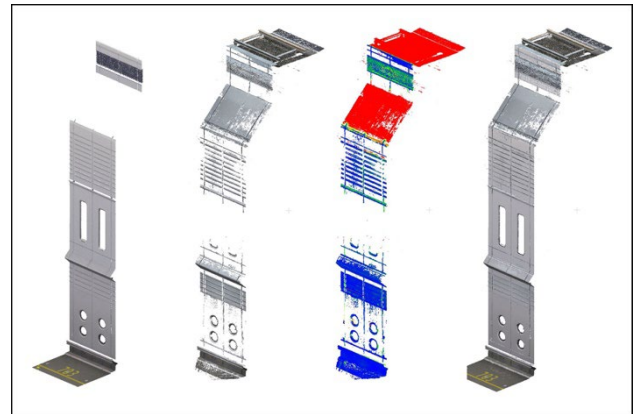

**Figure 10.** Comparison of the laser scan and SfM surveys. From left to right: laser scan, SfM, SfM showing overlap with scan, combination of the two

However, a few gaps remain in the upper parts and all panels could not directly be converted into accurate meshes for reproduction. With the current state of technology, improvements in drone surveying discussed above could correct the remaining flaws in the final model and extend the validity of this workflow to any type of High-Tech architecture.

### 3.3 From point cloud to panel manufacturing

Once a dense point cloud of the façade elements created with a laser scanner and/or drone photogrammetry has been cleaned, the following step is to mesh the geometry with appropriate software (in this case Agisoft Metashape). If necessary, further improvements of the mesh can be applied through re-meshing and trimming. In case of surface irregularities, the mesh model could also serve as a base for a new 3d model for fabrication, analog to the case study of the "CLA". In the case of metal 3d printing, a defined thickness, rear reinforcements, or connecting parts might be added at the non-visible side of the element. Yet for other production techniques like incremental robotic sheet forming or compression molding on 3d printed formwork, a high-quality mesh might be sufficient. In the case of the "Briefzentrum", data of construction details was more accessible, as some original plans (still hand-drawn) were found



in the Swiss Post archive on site. These documents present a valuable perspective on the construction of the parts located behind the aluminum skin without necessitating its disassembly. Nevertheless, it is anticipated that the digital manufacturing process of a spare part will prove to be rather intricate.

#### 4. DIGITAL FABRICATION STRATEGIES FOR REPAIR

The defect of a complex building element can be remedied in two different ways: The first option is to digitally fabricate a spare part as a targeted replacement to keep as much of the original substance of the overall façade construction in place. This can be done following either an additive or subtractive manufacturing rationale, by leveraging metal 3d printing or CNC milling. Several factors, including sustainability, resource efficiency, and economics must be considered when selecting this approach. Targeted replacement not only provides a resource-efficient solution but also conserves the remaining original façade by keeping it in place. Alternatively, the second option is to repair the original defective component directly, which can be achieved using laser metal deposition technology. For this approach, the damaged component needs to be demounted and transported to a laboratory<sup>8</sup>, where material can be precisely applied to the weak points, allowing for the original substance to be repaired. (Jambor, 2012) A successful application of this strategy prolongs the lifespan of the defective building component promoting its conservation. Consequently, it remains to be discussed whether only the component needs to be repaired or whether the next step is to decide on a structural upgrade<sup>9</sup>. In addition to restoring the initial condition of the component by repairing the diagnosed weak points, it is possible to enhance its strength by precisely adding material to specific areas. (Candel-Ruiz and Metzger, 2011) This significantly increases the lifespan of the element. Recent research in Wire-and-Arc Additive Manufacturing (WAAM) has demonstrated promising applications for reinforcing steel beams in existing buildings by targeting specific points with additional material. In both cases, however, these measures alter the appearance and surface quality of the building element, rendering them hardly adequate for the application to the small, worthy of protection, and historically valuable building stock. However, for reasons of resource efficiency and sustainability, this approach appears all the more promising for the repair and gradual extension of the lifespan of the general building stock.

#### 5. CONCLUSIONS

The aging construction heritage of the 1980s brings about unprecedented challenges in the field of preservation. As there is no preexisting basis to safeguard the materials, concepts, and techniques of High-Tech architecture, novel documentation and preservation strategies must be developed. In this paper, the application of current surveying and repair methods has been investigated based on two case studies, with the aim of reducing the impact of such interventions on original structures. To

develop tailor-made and low-cost interventions without the need for a systematic dismantling of facade components, the focus was set on the on-site documentation of building elements. As regards surveying, the "CLA" and "Briefzentrum" cases have required the development of unconventional strategies to document building components that are often hardly accessible, repetitive, uniform, and reflective. The limitations of today's surveying methods in this new context were overcome by carefully choosing lighting conditions, but also by leveraging non-reflective deposits and markers on the surfaces. Moreover, it has been shown that the combination of different surveying techniques can provide a satisfactory solution when it comes to documenting large-scale buildings. Concerning the reproduction of damaged components, both the conversion of point clouds into 3d meshes and the reverse engineering of building parts based on a few guiding geometries have been investigated. At this stage, because creating precise models from on-site surveys remains challenging, the second approach provides the best results as it efficiently eliminates imperfections in the surveys. However, the first approach has the potential to record accurately subtle deviations from an ideal geometry, hence retaining information about the manufacturing, assembly, and life of the repaired element. Finally, the feasibility of remanufacturing spare parts with 3d printing has been demonstrated using nylon and PLA models. As a next step, research will focus on the reproduction of components using other materials and techniques, such as WAAM, laser metal deposition, and robotic incremental forming.

#### REFERENCES

- Buchanan, P., 1983: High-Tech. Another British thoroughbred, *Architectural Review*, 174, 15–18.
- Candel-Ruiz, A., Metzger, J., 2011: Reparaturlösungen für höchste Ansprüche, *LTJ* 8, 42.
- Hotz, T., [K., B.,] 1987: Neuere Bauten, *Werk, Bauen + Wohnen*, 11/1987, 20-28.
- Jambor, T., 2012: Funktionalisierung von Bauteiloberflächen durch Mikro-Laserauftragschweißen, Diss. RWTH Aachen, 4.
- Kolarevic, B., 2001: Digital Fabrication. Manufacturing Architecture in the Information Age. *Reinventing the Discourse - How Digital Tools Help Bridge and Transform Research, Education and Practice in Architecture*, Buffalo (New York) 2001, 268-278. <https://doi.org/10.52842/conf.acadia.2001.268>
- Lanzara, E., Catello, D., Casciello, M., 2022: Scan to HBIM for complex reflective metal artefacts. 3d digitization and restoration, *The International Archives of the Photogrammetry, Remote Sensing and Spatial Information Sciences*, XLVIII-2/W1, 121-128. <https://doi.org/10.5194/isprs-archives-XLVIII-2-W1-2022-121-2022>
- Vögtlin, R., 1986(a): A New Gateway to Zurich, *The Sun*, internal corporate newspaper of Alusuisse, 15/1986, 1-9.
- Vögtlin, R., 1986(b): Aluminum. The ideal building material for weatherproof facing, *The Sun*, internal corporate newspaper of Alusuisse, 15/1986, 12.

<sup>8</sup> Especially when dealing with high-value, listed objects, demounting a component is, if possible, to be avoided since it bears a critical risk of damaging the component as well as its surrounding structure.

<sup>9</sup> In the publication "Upgrade: Making Things Better" (2022) by Silke Langenberg (ed.), the lack of reparability of everyday objects is addressed. At the same time, exemplary repairs and upgrades of everyday items are illustrated and discussed.