





# A Wireless Neural Stimulator IC for Cortical Visual Prosthesis

## Other Conference Item

### Author(s):

Lee, Jungho; Letner, Joseph; [Lim, Jongyup](#) ; Sun, Yi; Jeong, Seokhyeon; Kim, Yejoong; Koo, Beomseo; [Atzeni, Gabriele](#) ; [Liao, Jiawei](#) ; Richie, Julianna; Valle, Elena Della; Patel, Paras; [Jang, Taekwang](#) ; Chestek, Cynthia; Phillips, Jamie; Weiland, James; Sylvester, Dennis; Kim, Hun-Seok; Blaauw, David

### Publication date:

2023-07-24

### Permanent link:

<https://doi.org/https://doi.org/10.3929/ethz-b-000627848>

### Rights / license:

[In Copyright - Non-Commercial Use Permitted](#)

### Originally published in:

<https://doi.org/10.23919/vlsitechnologyandcir57934.2023.10185375>

# A Wireless Neural Stimulator IC for Cortical Visual Prosthesis

Jungho Lee<sup>1</sup>, Joseph Letner<sup>1</sup>, Jongyup Lim<sup>1</sup>, Yi Sun<sup>1</sup>, Seokhyeon Jeong<sup>1</sup>, Yejoong Kim<sup>1</sup>, Beomseo Koo<sup>1</sup>, Gabriele Atzeni<sup>2</sup>, Jiawei Liao<sup>2</sup>, Julianna Richie<sup>1</sup>, Elena della Valle<sup>1</sup>, Paras Patel<sup>1</sup>, Taekwang Jang<sup>2</sup>, Cynthia Chestek<sup>1</sup>, Jamie Phillips<sup>3</sup>, James Weiland<sup>1</sup>, Dennis Sylvester<sup>1</sup>, Hun-Seok Kim<sup>1</sup>, David Blaauw<sup>1</sup>

<sup>1</sup>University of Michigan, Ann Arbor, MI, USA, <sup>2</sup>ETH Zürich, Zürich, Switzerland, and <sup>3</sup>University of Delaware, Newark, DE, USA. (email: junghol@umich.edu)

## Abstract

We propose a 0.25 x 0.25 x 0.3 mm (~0.02 mm<sup>3</sup>) optically powered mote for visual cortex stimulation to restore vision. Up to 1024 implanted motes can be individually addressed. The complete StiMote system was confirmed fully functional when optically powered and cortex stimulation was confirmed in-vivo with a live rat brain.

## Introduction

Restoring vision is one of the most sought after and impactful biomedical pursuits. Retinal prostheses stimulate the *retina* to create vision. However, the ‘high acuity’ region of the retina is only 0.3 mm in diameter (0.07 mm<sup>2</sup>), making high resolution stimulation difficult. This same high acuity region is magnified by > 3 orders of magnitude in the *human visual cortex* to an area of 1 cm<sup>2</sup> providing sufficient space for high resolution microstimulation. Cortical stimulation can also treat optic nerve disease, whereas retinal prostheses require a healthy optic nerve to send signals to the brain.

A visual cortex prosthesis (VCP) requires a high electrode count (> 100) to achieve reasonable visual resolution [5]. A number of miniature wireless brain stimulation systems were proposed [1-4] that measure between 6 and 500 mm<sup>3</sup>. This is sufficiently small for applications requiring few stimulation channels (e.g., deep brain stimulation and restoring mobility), but does not allow sufficient *implantation density* with sufficient density for vision restoration. In addition, these methods have not demonstrated *multi-access* stimulation control.

A key challenge for VCP is that they must stimulate 100s of distinct cortical neurons in a cm<sup>2</sup> region. Each stimulation channel should be independent and have variable output (minimum 7 levels, or 3 bits) with a minimum update rate of several Hz and a stimulation rate of > 50 Hz for flicker fusion in humans. The motes must therefore be individually addressable, and the mote cluster must support a high data rate (> 5 kbps). One approach is to use a single cm<sup>2</sup> sized electrode array with 100s of electrodes, however, the resulting rigidity will evoke brain scar tissue formation due to brain micro-motion, limiting electrode lifetime. Hence, there is an unaddressed need for a sub-mm<sup>3</sup>, free-floating stimulation unit that is designed for high-density placement (> 100s of units in a 1 cm<sup>2</sup> area), with individual addressing and stimulation control.

Hence, we propose an optically powered stimulation mote, called StiMote, which is individually addressable and can support up to 1024 units operating with 7 intensity levels at 50 Hz stimulation rate and 2.5 Hz intensity update rate. StiMote utilizes a custom designed GaAs PV/LED chip [6] for near-infrared (NIR) power transfer and bi-directional optical communication. Using a single discrete 100 nF charge storage capacitor (0.004 mm<sup>3</sup>), StiMote generates a balanced, bi-phasic, switched-capacitor stimulation current. Ultra-low power design results in 5.5  $\mu$ W power consumption allowing a system size of 0.25 x 0.25 x 0.3 mm (~0.02 mm<sup>3</sup>). The complete StiMote system was bench-top tested and is fully functional. Stimulation capability was confirmed using an *in-vivo* stimulation test using a live rat brain.

## Proposed Design

StiMotes are placed free-floating on the cortex and are controlled by a cm-sized repeater unit (RU) in the skull that can communicate wirelessly with an outside interface unit (Fig. 1). Recent stimulation motes have used inductive coupling [1–2] for power transfer, which suffers from rapid antenna efficiency degradation or tissue absorption when scaled below 1 mm dimensions. Ultrasonic transducers [3] have good tissue transmission properties but suffer from large size. StiMote uses *optical power / data transfer* to take advantage of the *linear scaling* of photovoltaic (PV) power with diode area, enabling PV cells to maintain high efficiency down to sub-mm dimensions.

Up to 1024 StiMotes in a 1 cm<sup>2</sup> area, can be powered using their custom GaAs PV chip layers from a single global light source at the

RU (Fig. 1). This PV layer has a *dual-purpose* photodiode (PD) / LED for bi-directional data communication, avoiding the extra area required for two *separate* structures. The PV and CMOS layers are thinned to 50  $\mu$ m and bonded together, as seen in the assembled dummy device in Fig. 9 (d). A platinum-iridium coated carbon (PtIr-CF) electrode [7] decreases electrode tissue impedance by >10 $\times$  and is electrically and mechanically anchored to the CMOS chip using a through-silicon via terminating in metal 1.

Each StiMote has an individually controlled 3b stimulation charge resolution. The StiMote system uses time-division-multiple access (TDMA) communication where all motes synchronize to a global clock continually transmitted by the RU. At initial mote configuration, each StiMote is individually addressed based on its unique 16b PUF (physically unclonable function) ID [8] and assigned a unique TDMA time slot. The RU cycles through all PUF IDs and when a mote recognizes its ID, it identifies itself to the repeater using its LED and stores its TDMA time slot. After StiMotes are configured, the RU communicates images by transmitting an initial 10b synchronization code followed by 1024 3-bit TDMA data slots. The synchronization code is guaranteed not to occur in an actual TDMA data stream by modifying any matching modulation sequence as needed by flipping one intensity level LSB, which was shown to have negligible impact on image quality. This TDMA approach reduces the required bandwidth by 30 $\times$  compared to individually addressing each mote with an address followed by its modulation level, thereby reducing *optical receiver power* and StiMote size.

The CMOS layer of StiMote contains the optical link and stimulation control circuits (Fig. 2). The optical receiver uses a Manchester-encoded current-mode signal, which it amplifies with a transimpedance amplifier (TIA) and oversamples at a 10-20 $\times$  rate (Fig. 3). The processor detects the predefined sync code followed by an instruction for configuration and stimulation commands (Fig. 4).

The stimulation circuits consist of a phase controller and charge balance circuit to equalize the bi-phasic charges and avoid electrode degradation due to metal-ion diffusion (Fig. 6). A DC-DC upconverter generates 4.5 V on the 100 nF discrete storage cap which the stimulation driver draws from using a *switched capacitor* charge injection approach. This maximizes the injection *efficiency* but complicates the charge balancing since both current and voltage vary during the injection. To address this, the charge monitoring circuit (Fig. 6) mirrors the injection current (~10s-100s of  $\mu$ A) to a 0.4 pF on-chip capacitor ( $C_m$ ) by dividing it 16.6k times to reduce the on-chip cap area. When  $V_m$  exceeds  $V_{ref}$ ,  $C_m$  is reset. By counting the reset pulses the charge is modulated and equated between the two phases. The optical receiver amplifies a photodiode current-mode signal (10s of nA) to a voltage-mode signal (10s of mV) (Fig. 4). The TIA is designed for a gain of 129.1 dB $\Omega$  and bandwidth of 46.8 kHz. TIA outputs feed a comparator using the 150 kHz oscillator clock.

## Evaluation and Measurements

The proposed StiMote was fully functional when operated completely wirelessly using harvested light and 7.5 kbps optical data transmission (Fig. 5). Bench-top measurement results show 0.2 nC phase charge mismatch and good linearity across 3b modulation (Fig. 7). 10<sup>6</sup> pulses (16 nC, 50 Hz) were applied *in-vitro*. No bubble formation was observed on the electrodes during stimulation and impedance measurements verifying electrode integrity. A rat visual cortex was stimulated with a PtIr-CF electrode wired to the StiMote chip. Multiple nearby recording electrodes observed evoked neural signals and demonstrate that stimulation is effective and propagates across the visual cortex (Fig. 8). Table 1 provides a comparison with other stimulation systems. The proposed system marks the smallest wireless system and is the only one that is designed specifically for vision restoration and that can reach sufficient implant density.

References

[1] Y. Lo, *et al.*, ISSCC, 2016.  
 [2] Y. Jia, *et al.*, ISSCC, 2018.  
 [3] B. C. Johnson, *et al.*, CICC, 2018.  
 [4] Z. Yu, *et al.*, ISSCC, 2020.  
 [5] K. Cha, *et al.*, Ann Biomed Eng, 1992.  
 [6] Y. Sun, *et al.*, PVSC, 2022.

[7] E. della Valle, *et al.*, Front. nanotechnology, 2021. [8] K. Yang, *et al.*, ISSCC, 2017.

Acknowledgement

We thank National Science Foundation (NSF award CBET-2129817) for support.

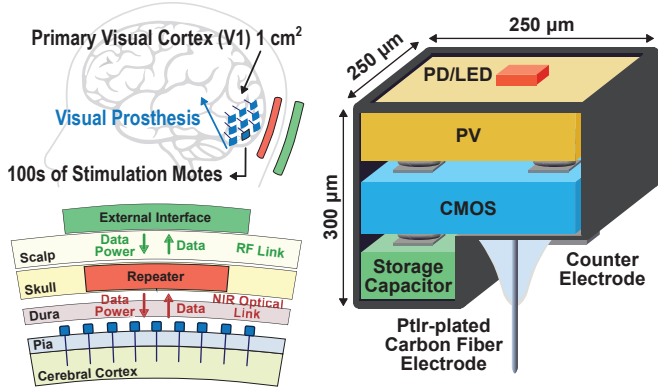

Fig. 1. Conceptual overview of the proposed free floating stimulation motes, their communication, and the 3D stack of chip layers with dimensions.

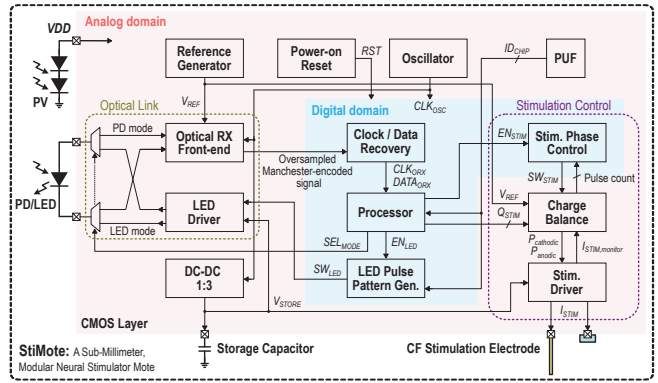

Fig. 2. Top-level diagram of the StiMote system, with emphasis on CMOS-layer blocks.

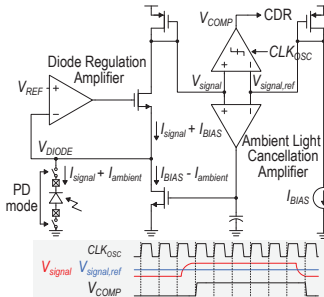

Fig. 3. TIA structure and its operation for optical receiver with ambient light cancellation.

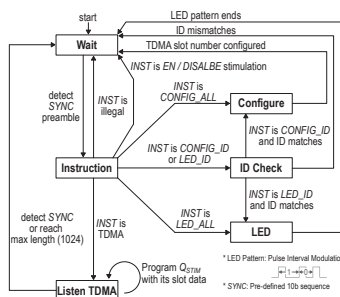

Fig. 4. Processor state diagram for communication between StiMote and RU.

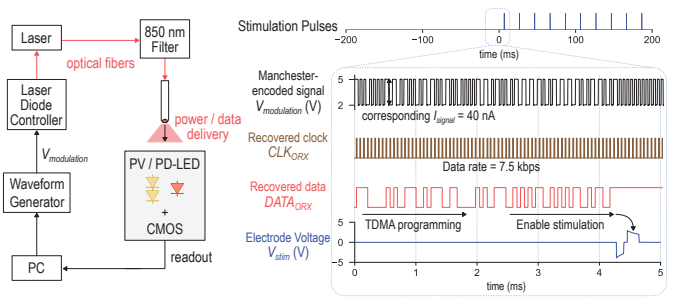

Fig. 5. Optical testing setup and measured waveforms showing 7.5 kbps data rate when a 40 nA photodiode current is modulated by 850 nm NIR laser.

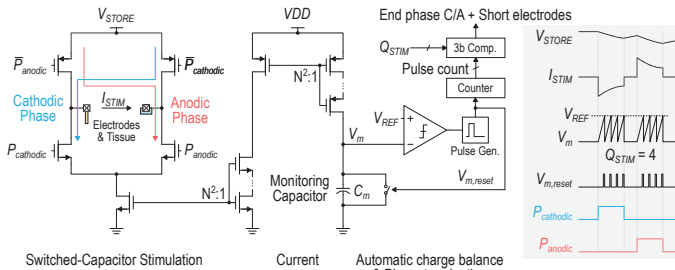

Fig. 6. Stimulation control stages for charge balancing and its operation. Current is copied with 16.6k reduction and threshold crossings are counted to track and balance charge.

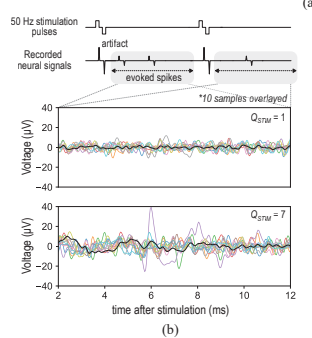
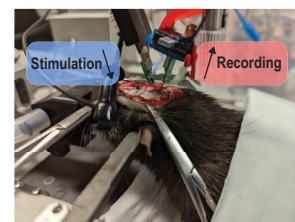
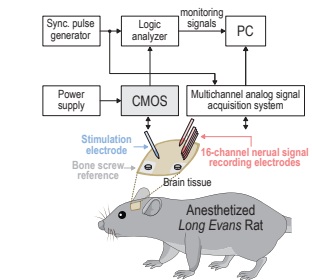

Fig. 8. (a) *In vivo* testing setup, (b) evoked neural signals after a stimulation pulse, (c) average evoked spikes per stimulation across charge modulation codes for 16 recording electrodes.

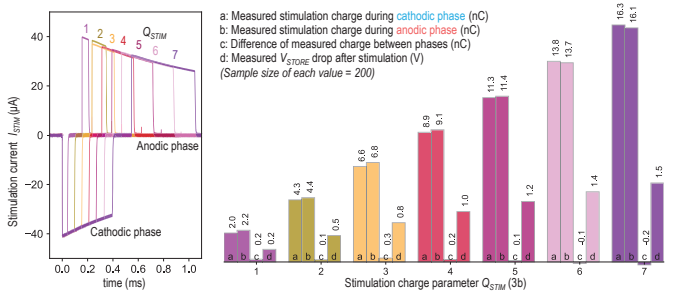

Fig. 7. Measured waveforms (left) and charge balancing characteristics (right) including integrated charge during each phase for different  $Q_{STIM}$  with a 100-kΩ electrode model.

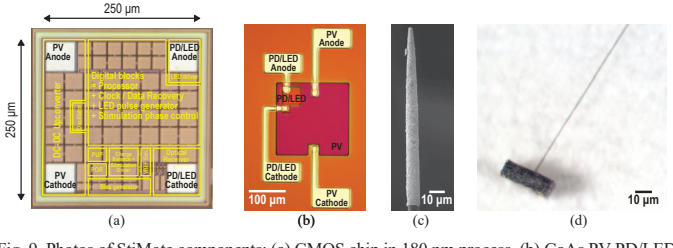

Fig. 9. Photos of StiMote components: (a) CMOS chip in 180 nm process, (b) GaAs PV-PD/LED cell, (c) PtIr-plated CF electrode, and (d) a dummy mote with stacked CMOS and GaAs layers.

Table I. Comparison with state-of-the-art wireless stimulation approaches

	This Work	ISSCC '16 [1]	ISSCC '18 [2]	CICC '18 [3]	ISSCC '20 [4]
Application target	Brain (Visual Cortex)	Spinal Cord	Brain	PNS	Spinal Cord
Power / Data delivery	Optical	Inductive	Inductive	Ultrasound	Magnetolectric
Process	180 nm	180 nm HV	350 nm	65 nm	180 nm
Implant volume (mm <sup>3</sup> )	0.02	500	12.15	6.5	8.2
Chip area (mm <sup>2</sup> )	0.0625	25.1	1	0.06	1.5
External components	1 Cap	6 Cap	4 Cap	1 Cap	1 Cap
	1 Stacked PV-PD/LED	2 Coil	1 Coil	1 Piezo	1 ME Film
Multiple access	Yes	No	No	No	No
Supported number of stimulation sites	1024	1	1	1	1
Stimulation Channels per chip	1	160	16	1	1
Stimulation Shape	Biphasic	Biphasic	Monophasic	Monophasic	Biphasic
Stimulation Type	Switched Cap. Current	Constant Current	Switched Cap. Optical	Constant Voltage	Constant Current
Max stimulation frequency	50 Hz	20 kHz	10 Hz	2 kHz	200 Hz
Max stimulation current (mA)	0.4	0.5	10	0.4	1.5
Stimulation resolution (bit)	3	7	4	3	5
Power w/o stimulation (μW)	5.5	864	300	4	23.7
Supply voltage (V)	1.55	±6 - ±12	1.8	2.5	2.05
Max Data rate	7.5 kbps	2 Mbps	50 kbps	-	7.8 kbps