

# Script to Structural Geology

## **Educational Material**

**Author(s):**

Burg, Jean-Pierre

**Publication date:**

2018

**Permanent link:**

<https://doi.org/10.3929/ethz-b-000279493>

**Rights / license:**

In Copyright - Non-Commercial Use Permitted

# FOLDS

The term **fold** is used when one or stacks of originally flat and planar surfaces such as sedimentary beds become bent or curved as a result of plastic (i.e. permanent) and ductile deformation. Folds in rocks vary in size from microscopic crinkles to mountain-size folds. They occur singly as isolated folds and in extensive **fold trains** at all scales. A set of folds distributed on a regional scale constitutes a **fold belt**. Fold belts are typically associated with convergent plate boundaries and directed compressive stress.

## Experimental fold

after Willis (1893)  
13th Ann. Rept. U.S. Geol. Surv.  
pt. 2 p. 247



Folds form under varied conditions of stress, hydrostatic pressure, pore pressure, and temperature as evidenced by their presence in sediments, sedimentary rocks, the full spectrum of metamorphic rocks, and in some igneous rocks. Folds may result from a primary deformation, which means that folding occurred during the formation of the rock, or a consequence of a secondary, i.e. tectonic deformation. Slumps in soft sediments and flow folds in lavas are examples of primary folds. In structural geology we are mainly concerned by the tectonic folds that are, in general, produced by a shortening component parallel to the layering of the rocks. Their spectacular presence in shear zones and mountain belts indicates that distributed, ductile deformation has resulted in gradual and continuous changes in a rock layer both in its attitudes and internally. However, it must be remembered that the absence of folds does not demonstrate the absence of pervasive deformation.

This lecture deals with the description and morphological classification of folds. Such classifications aim at using the geometry and degree of evolution of folds as indicators of the amount of deformation, hence displacement and strain patterns involved in the development of deformed areas. It is still difficult to extract dynamic or kinematic information from these structures since their shapes in rocks are highly variable. This variability reflects differences in several types of parameters such as layer thickness, initial layer irregularities, strain intensity, deformation path, rheology and degree of anisotropy.

## Folded single surface - basic geometrical definitions

A fold may bend a single surface, or affect one layer bounded by two surfaces or deform a stack of layers with several interfaces. Since there is considerable variation in fold morphology a proliferation of terms has developed to describe qualitatively these structures. For convenience, it is first easier to define folds on a single surface.

### Morphology of a folded surface: Hinge, limb, inflections

The radius of curvature of a folded surface varies progressively from point to point. The point of smallest radius of curvature is called the **hinge**. It is flanked by two areas of larger radius of curvature: the **limbs**.

Folds are three-dimensional structures. Connecting the hinge points on a specific folded surface defines the **hinge line** or **fold axis**. The fold axis is the most important structural element of a fold

because it shows the direction of maximum continuity of this fold. Some folds (e.g. **box folds**) may have several hinge lines.

The **inflection points** are points of zero curvature, where the sense of curvature changes from a convex to a concave line. They usually are aligned on either limb of a fold;

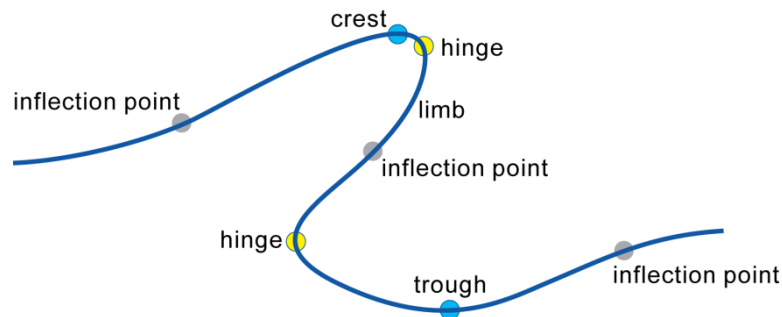

Basic terminology on a folded single surface

The limb may be then redefined as the fold segment between a hinge line and the adjacent **inflection line**, which is the locus of inflection points. If the limb has a straight segment, its midpoint is conveniently taken as inflection point.

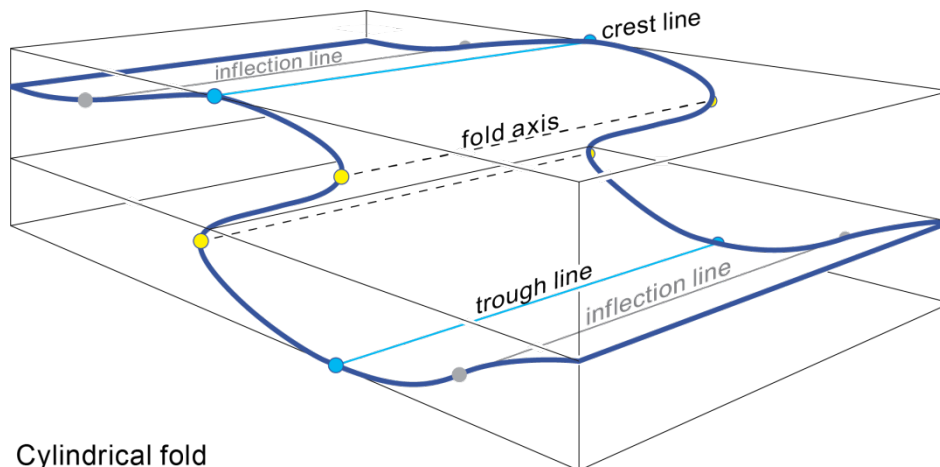

Cylindrical fold

### Antiform and synform

A convex-upward fold is an **antiform**; a convex-downward fold is a **synform**. They often come in pairs. The region towards the inner, concave side of a folded layer is the **core** of the fold. The convex and concave sides of a folded layer are also distinguished as the **extrados** and the **intrados**, respectively. **Anti-** and **synclinorium** are large (megascopic, regional-scale) anti- and synforms, respectively.

An oval-shaped antiform with no distinct trend of the hinge line, in which layering dips outward from a central point, is termed a **dome**, a synform with no distinct trend of hinge line, i.e. in which layering dips inward toward a central point, is a **basin**.

Folds that are neither antiformal nor synformal, whose limbs converge sidewise, are called **neutral folds**. They comprise vertically plunging folds, folds-with horizontal axial surfaces, and folds that plunge parallel to the dips of their axial surface.

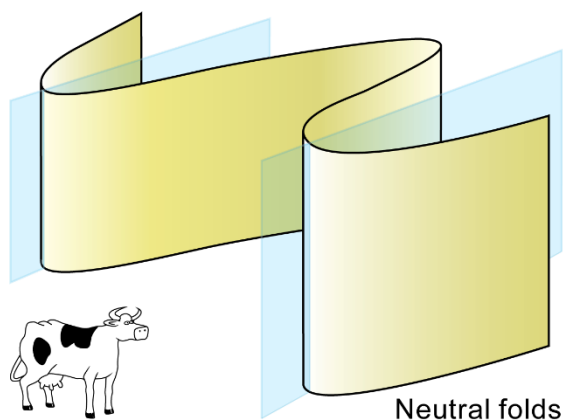

### Anticline and syncline

Anticline and syncline are terms with stratigraphic significance. Anticlines have older strata in the core. Synclines have younger strata at the core. In simply-folded areas, anticlines are antiform and synclines are synform. But **antiform synclines** and **synformal anticlines** may exist in refolded regions. In these regions it is important to determine the **younging direction**, which is the direction in which the strata become younger along the axial surface.

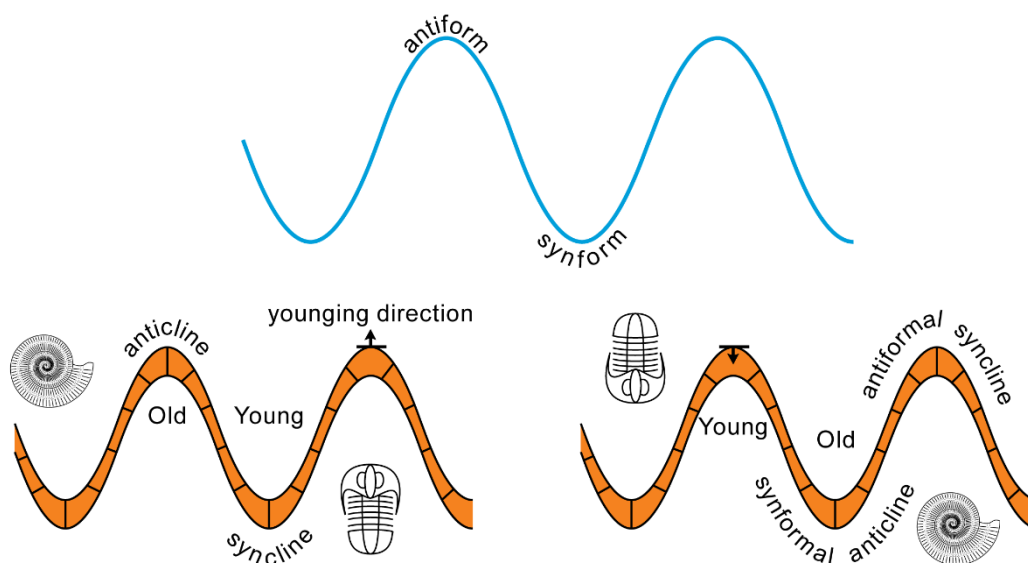

### Profile

A folded surface is fully described in a plane perpendicular to the fold axis. The **transverse profile** (or simply profile) of a fold is the section drawn perpendicular to the fold axis and its axial surface; this contrasts with a geological section which is normally drawn in a vertical plane.

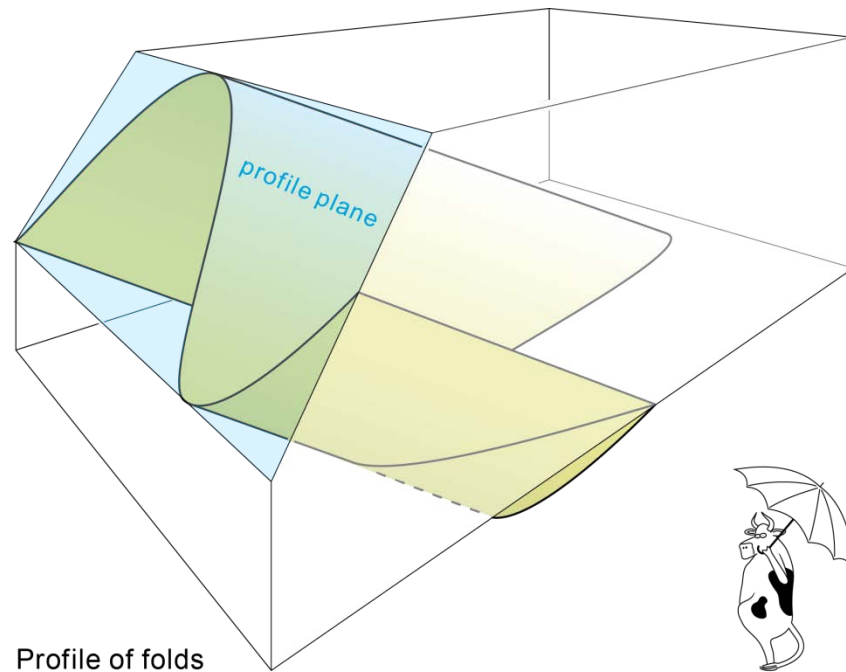

The profile is a reference plane used to describe and measure all geometrical characteristics of the fold: height or amplitude, wavelength, tightness, roundness. Indeed, these aspects vary with the angular relationship between any section plane and the folded surface.

Influence of the obliquity of the section on the apparent fold tightness

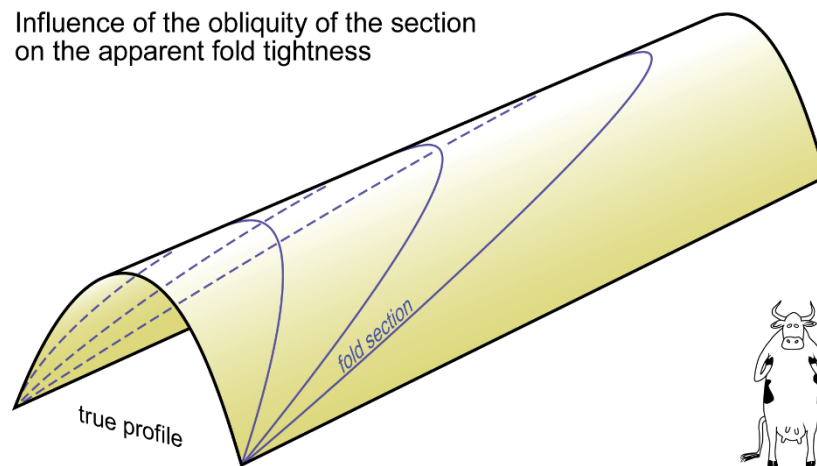

Together, all various geometrical features of the fold profile and the orientation of the fold axis define the **style** of a fold.

### Crest, culmination and trough

The **crest** is the highest point of an antiform, the lowest point of a synform is the **trough**. Imaginary lines joining crest and trough points of any bedding surface are **crest lines** or **trough lines**. They are also the lines where layering changes orientation from dip in one direction to dip in the opposite direction, away from each other along the crest line, toward one another along the trough line. Crest and trough lines are neither horizontal nor rectilinear but vary in height along their length. The high points in crest lines are referred to as **culminations** and the low points in trough lines are **depressions**.

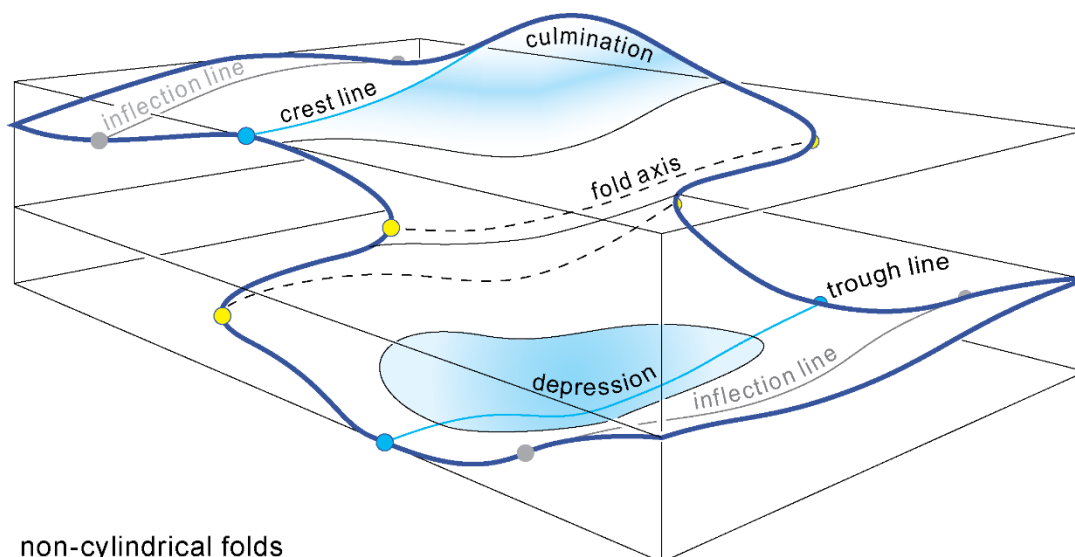

non-cylindrical folds

### Interlimb angles

In profile, the smaller angle made by the limbs of a fold is termed the **inter-limb angle**, a measure of the **tightness of the fold**. It is the angle subtended by the tangents at two adjacent inflection points, which may reflect the intensity of compression.

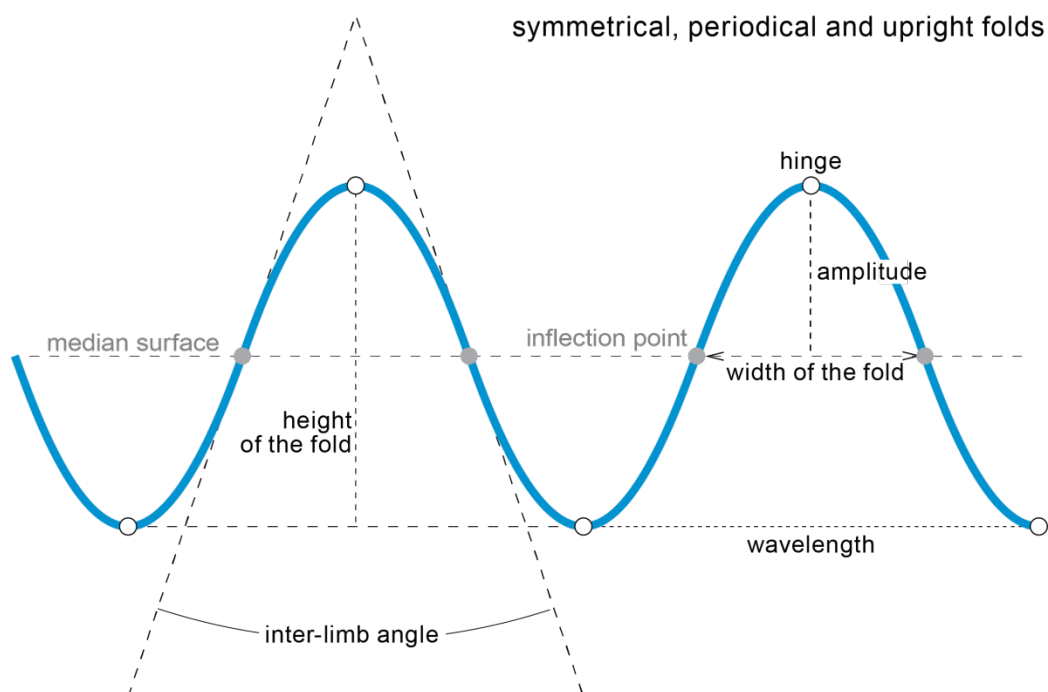

symmetrical, periodical and upright folds

A qualitative classification based on the interlimb angle, separates five tightness classes:

inter-limb angle	tightness class
180 to ca. 120°	Gentle
120 -- 70°	Open
70 -- 30°	Close
less than 30°	Tight
0°, i.e. parallel limbs	Isoclinal
< 0°	Fan

Qualitative classification of folds according to interlimb angles

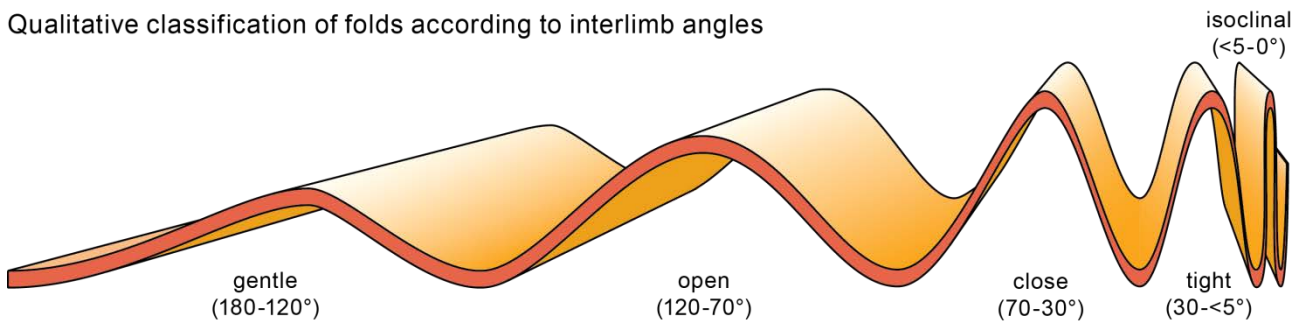

**Fan folds** have negative interlimb angles.

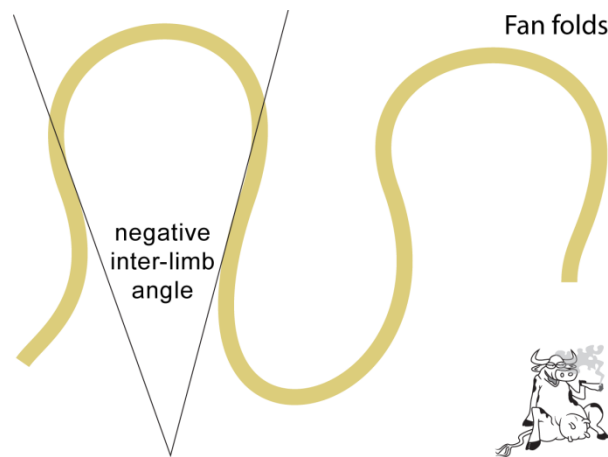

A **culsp** is a fold where both hinge and inflection points are the same point; in other words the fold has no inflection point. Its **tightness** is defined by a cusp-angle between the tangents to the folded surface at the cusp.

### Fold closures

The **fold closure** indicates the direction in which the limbs converge. For example, a fold closes westward. The shape of the fold closure depends on how the curvature of the folded surface changes around the hinge; it may be very sharp and the limbs relatively straight, or the curvature more regular around the fold. Fold closures are thus qualitatively described as **rounded** or **angular**. **Arrowhead folds** or **flame folds** have sharp hinges with distinctly, often sigmoidally curved limbs.

**Kinks** are folds with straight, planar limbs (there is no inflexion point) and angular hinges (the hinge zone is reduced to a point). They form in strongly anisotropic rocks in which the well-developed anisotropy is either thin laminated beds or foliation planes. Where kinks are markedly asymmetrical, the long narrow zone defined by the tabular, short limb is referred to as a **kink band** and the axial plane traces are referred to as **kink band boundaries**.

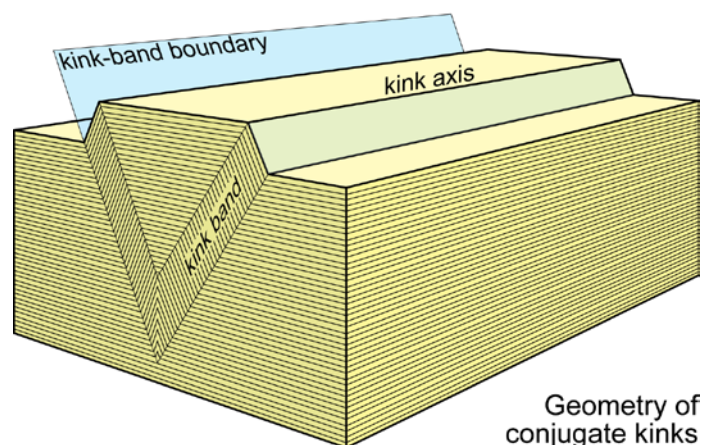

The **bluntness ratio** is a quantitative measure of how round or angular the hinge is. It is defined as  $B = r_h/r_i$  where  $r_h$  is the radius of curvature at the hinge and  $r_i$  the radius of the circle tangent to the limbs at the two inflection points. The angle  $\theta$  between the two  $r_i$  is sometimes used to define the **tightness** of the fold.

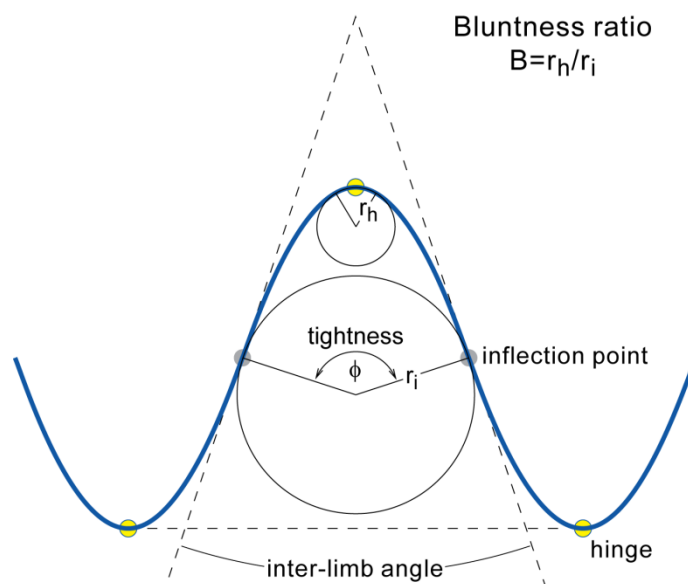

## Cylindricity

### *Cylindrical folds*

Folds are often drawn as **cylindrical** structures, meaning that the fold axis is a straight line which, when moved parallel to itself, generates any single fold of the same generation. The axis of cylindricity is parallel to the fold axis. In three dimensions, a cylindrical fold appears as a straight line in a section parallel to its axis, whereas in any other section the trace of the folded surface has a wavy shape.

### *Doubly plunging folds*

However, hinge lines are rarely straight. **Non-cylindrical** folds deviate from the ideal cylindrical geometry. Hinges of non-cylindrical folds are curved within a plane (**curvilinear**) and, therefore, change in trend and plunge. A **conical fold** describes a non-cylindrically folded surface that has the approximate geometry of a cone. The plunge of the hinge line reverses along a **doubly plunging** fold. If the hinge line plunges away from a high point (the axis is convex upward), the high point is a



**culmination**; if it plunges toward a low point (the axis is concave upward) the low point is a **depression**.

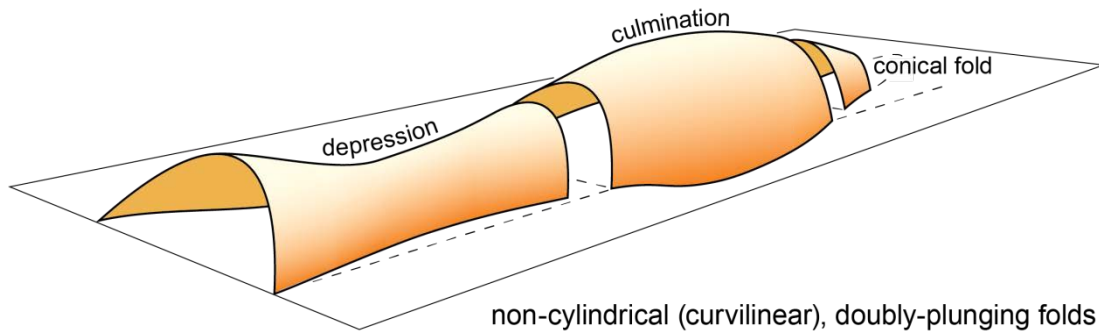

Nearly circular culminations and depressions are **domes** and **basins**, respectively.

### *Sheath folds*

A **sheath fold** has a strongly curved hinge line sweeping around through an arc of more than  $90^\circ$  up to hairpin bend. Sheath folds contain a long (stretching) axis along the length of the tube or tongue shape, whilst cross sections normal to this axis display closed geometries. Such elliptical sections or nested rings define **eye-folds**. These “tubular” folds generally reflect heterogeneous simple shear or flow superimposed on very simple buckles or perturbation of the simple shear flow such as, for example a foliation bulge around a rigid clast.

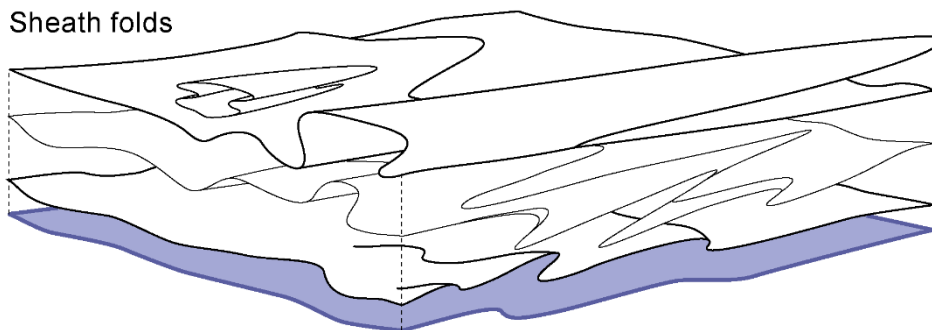

During fold amplification due to progressive shear, the fold axes may behave passively and rotate towards the shear direction until at high strain they become sub-parallel to the shear direction. Gentle bends of the initial buckle hinges are therefore accentuated during subsequent shearing to create folds with strongly curved axes. Sheath folds are therefore characteristic of strongly deformed parts of shear zones.

### *Buckling of an interface*

Buckle folding may also affect the planar interface between materials of contrasting viscosity. When this occurs, the folds have a characteristic form; those closing in one direction have a broad rounded shape (**lobate folds**) and hinges closing in the opposite direction have a narrow or cusped shape. The **cusps** always point towards the material with the higher viscosity. Thus, in outcrops dominated by cusped-lobate forms, it is possible to know at a glance which layers were relatively stiffer compared to adjacent beds at the time of folding. This is a common cause of mullion structures.

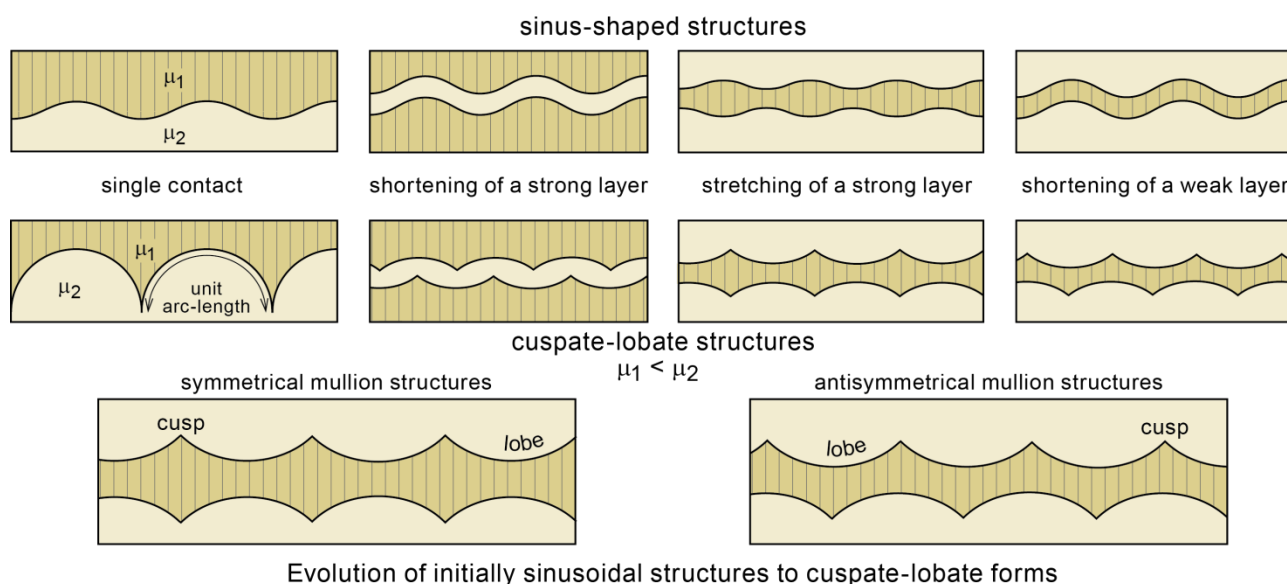

### Homocline - Monocline

A succession of beds with uniform parallel attitudes over a large area forms a **homocline**.

An antiform and an adjacent synform delimit a single limb. Such a flexure pair involving a local increase in regional dip (i.e. only one tilted, step-like limb in an otherwise subhorizontal or gently dipping sequence) constitutes a **monocline**. Conversely, a local decrease in regional dip is a **structural terrace**. Monoclines and structural terraces are typically large-scale structures along margins of broad basins or uplift platforms in cratons.

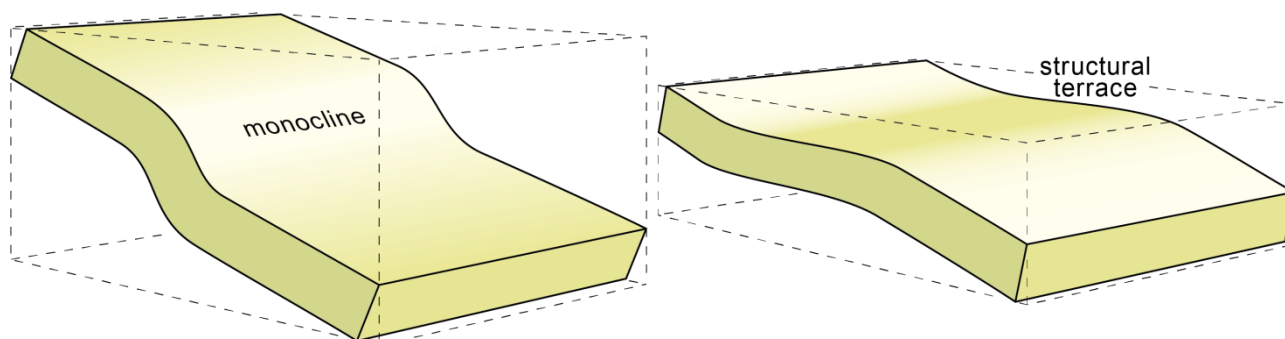

### Orientation of a plane

By definition, folding implies some rotation of the layering and this rotation may reach large finite values ( $90^\circ$  or more). As a consequence, folded areas are characterised by beds that are no longer horizontal, but instead inclined. First we must know how to measure and record the inclinations and their directions. The **attitude** is the orientation in space of any structure, which requires several measurements. Geometrically, we know that two intersecting lines define one single plane.

- The **strike** is the direction of the horizontal line within a sloping bed of rock (i.e. the intersection of an inclined geological plane with an imaginary horizontal surface).
- The **direction of dip**, the line of maximum slope on the bed, is perpendicular to the strike.
- The **dip** is the angle between the bed and the horizontal. It is measured in the imaginary vertical plane orthogonal to the strike (i.e. that contains the dip direction).

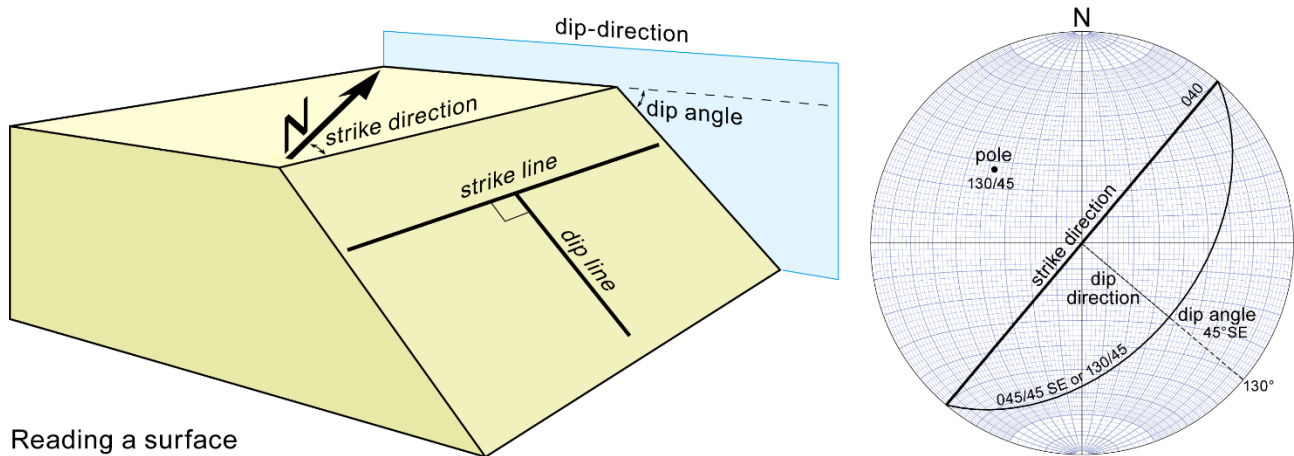

Reading a surface

The azimuth of the strike direction, the dip and the dip direction wholly define any geological plane.

### Fold systems and folded multilayers - more definitions

A fold may bend a single surface, or affect one layer bounded by two surfaces or deform a stack of layers with several interfaces. The two sides of a folded layer are also distinguished with respect to the fold core as the **outer arc** and **inner arc**, respectively. A **fold system** is a group of folds, often of variable shape, size and orientation, yet spatially and genetically related. Much of the geometry of folds is concerned with the shape of the profile. On the transverse profile, the wavy trace of the folded surface may be represented by a function  $y = f(x)$ , where the x-axis joins two consecutive inflection points and the y-axis (with positive y directed upward) is at a right angle to the x-axis. In this case, the inflection points are those where  $d^2y/dx^2 = 0$ . At a hinge point the absolute value of  $d^2y/dx^2$  will be maximal.

#### Orientation of folds

A fold, in general, affects several superposed layers. The imaginary surface connecting the hinge lines on successive layer surfaces of the same fold is the **axial plane**. This imaginary plane is often curved and equidistant from each limb and thus often bisects the angle between them.

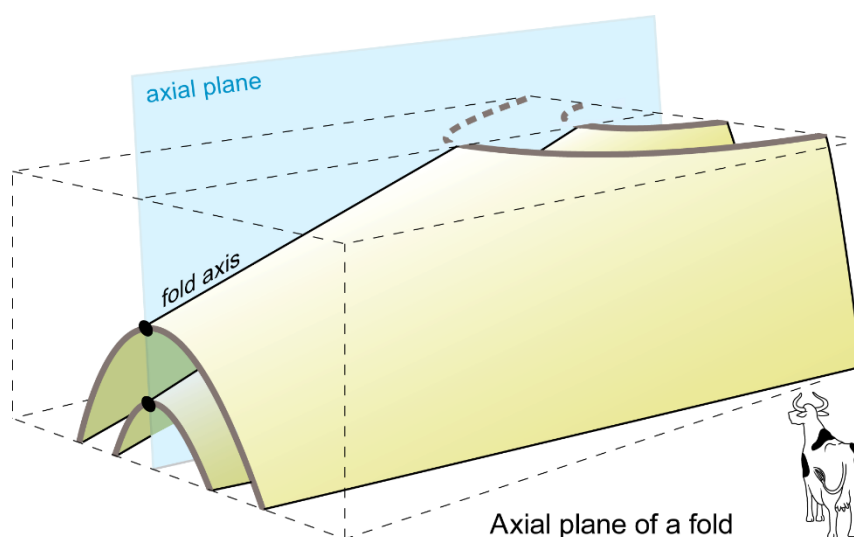

Axial plane of a fold

The orientation of folds is completely given by the fold axis treated as a line and the attitude of the axial plane (**strike** and **dip**), together.

A general rule is that both the trend and plunge of minor order folds can be used for extrapolation in fieldwork. They also indicate the trend and plunge of first order folds of the same generation.

### ***Fold axis orientation***

The orientation of a fold axis is expressed by its **plunge** and its **plunge azimuth**:

- The **plunge** is the inclination measured from the horizontal in the imaginary vertical plane containing the line).
- The direction of plunge (the trend) is the strike (azimuth, the bearing relative to North) of the imaginary vertical plane that contains the line and the direction in which the downward inclination occurs.

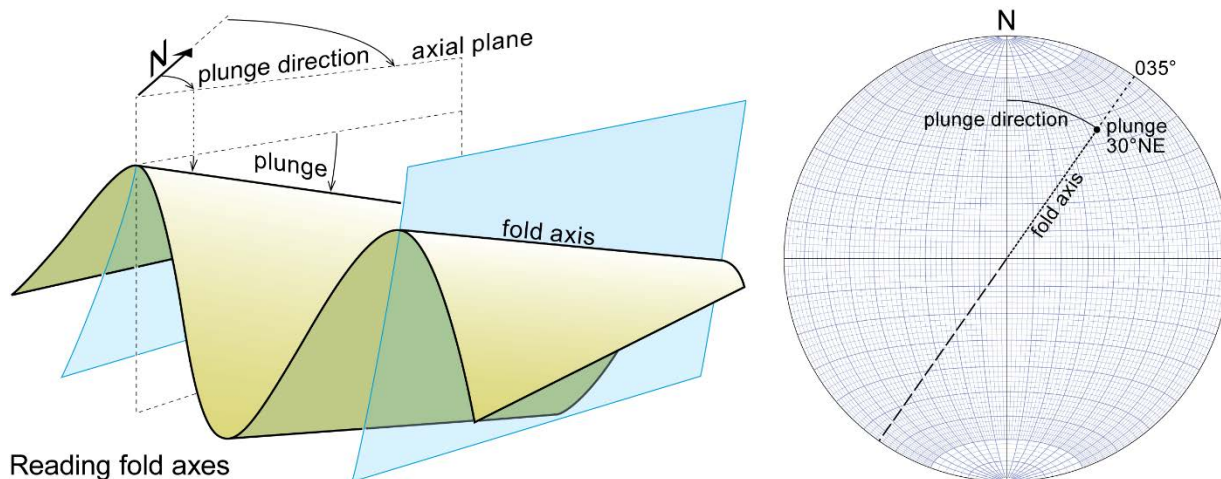

Reading fold axes

### ***Axial plane orientation***

The axial planes cuts the hinge zone of a folded surface along the fold axis. The orientation of the axial plane is expressed as a dip and strike or, in a more compact form, as a dip and direction of dip. As for any surface the strike is the trend of the horizontal line contained in the surface; the angle dip is the angle between the surface and the horizontal plane. The direction of dip of a surface is the trend of the line perpendicular to the strike of the surface looking down the dip.

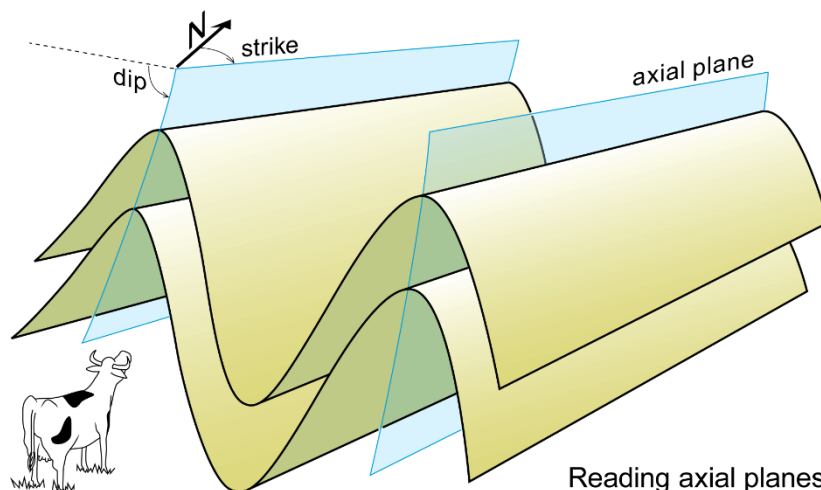

Reading axial planes

A semi-quantitative classification is valid for folds with subhorizontal axes.

**Upright** folds have approximately vertical axial surfaces.

Folds with dipping axial planes are **inclined** ( $80^\circ < \text{steeply} < 60^\circ < \text{moderately} < 30^\circ < \text{gently} < 10^\circ$ ) if the steeper limb has an upward-younging to vertical stratigraphy. The fold is an **overfold** if

both limbs dip in the same direction as the axial plane and the steep limb has an up-side-down stratigraphy.

Folds with sub-horizontal axial planes are **recumbent**. Fold nappes are large recumbent folds with inverted limb over several kilometers.

**Plunging folds** have axial planes rotated by more than  $90^\circ$ .

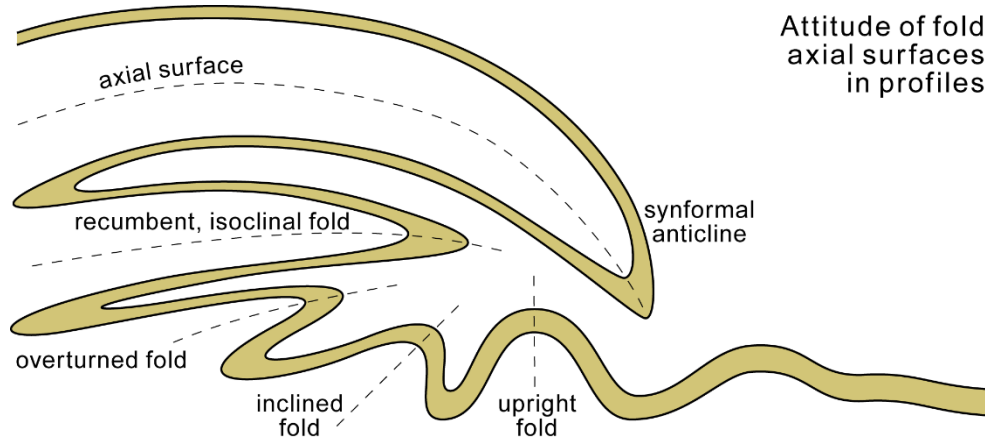

**Polyclinal folds** belong to groups of folds with sub-parallel hinge lines but non-parallel axial surfaces.

#### Layer thickness - parallel and similar folds

Changes in layer thicknesses reflect material properties of the fold. There are two end-member geometries: parallel and similar folds. Approximations to these two morphologies are found in rocks, but the majority of natural folds lies somewhere between the two. Furthermore, some layers may approximate one of the ideal morphologies while other layers do not.

#### **Parallel folds**

A fold is **parallel** if the layer thickness, measured normal to the bed, is constant all around the fold. In other words, the strata are bent in parallel curves. There are two types:

- Rounded forms have smoothly curved limbs and broad hinges.
- Angular forms have straight limbs and narrow hinge zones.

#### Rounded, parallel folds

In profiles of **concentric folds**, the folded surfaces define circular arcs with a common centre. This geometry generates a space problem. Rounded antiforms reduce downward to a point (**cusps**). Similarly, deep and wide synforms wedge out upward. This geometrical limitation requires that parallel folds die out at depth. Incompetent beds below the antiformal cusps are squeezed in the anticlines. The lower boundary of the incompetent levels remains essentially unfolded. The incompetent layer between the apparently undisturbed, flat footwall and the independently folded hanging wall is a “*décollement*” horizon.

## Effects of layer thickness on fold geometry

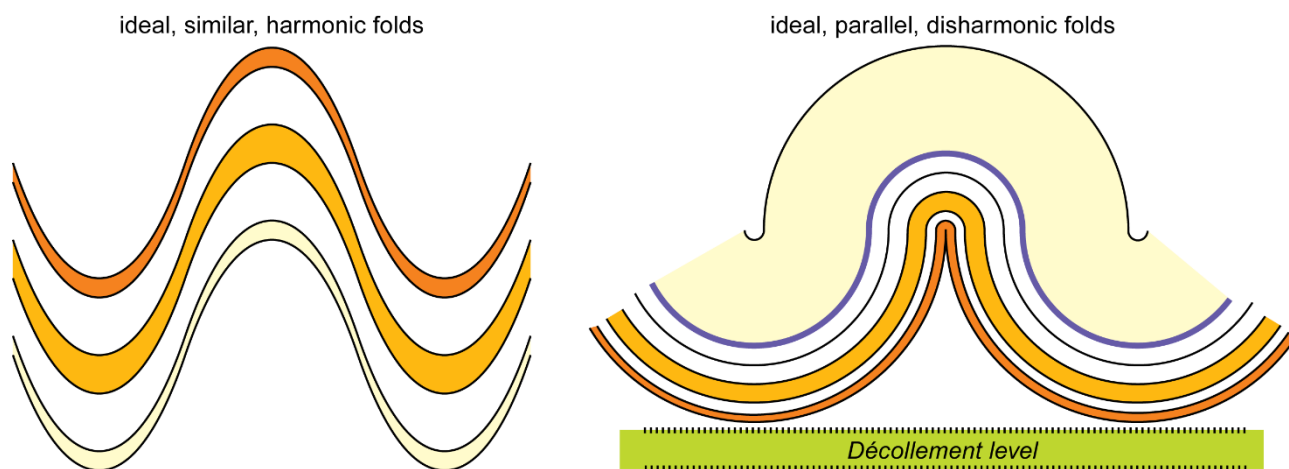

**Ptygmatic** folds (from πτυσσω, to buckle in ancient Greek) involve an irregularly folded, isolated “layer”, typically a quartzo-feldspathic vein in a much more ductile schistose or gneissic matrix. They occur in high-grade rocks, mostly migmatites as trains of rounded and near-parallel, commonly concentric folds in which the amplitude is large (>10) and the wavelength small with respect to the almost constant layer/vein thickness (meander-like pattern). They have a lobate, tortuous to squiggled appearance (for example, limbs fold back on themselves and the interlimb angle is negative) and tend to be polyclinal; however, they have no axial plane foliation.

Ptygmatic folds

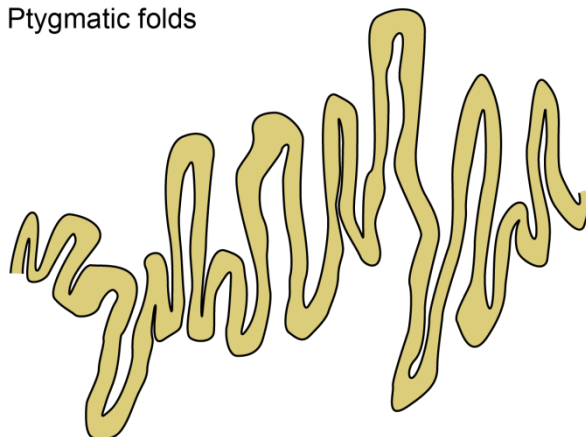

**Convolute** folds have markedly curviplanar axial surfaces and are generally disharmonic (adjacent layers do not have the same wavelength and amplitude). Like ptygmatic folds, they look like complexly contorted but regular structures without axial plane cleavage. They are characteristic of slumped soft sediments.

Angular parallel folds

**Chevron folds** are symmetric or slightly asymmetric folds with straight limbs, sharp angular hinges and often acute interlimb angles. They are common in multilayers of alternating competent and incompetent layers and thus combine both similar (in incompetent layers) and parallel (in competent layers) fold geometries. Asymmetrical chevron folds are also termed **zigzag folds**.

*Similar folds*

Folds in which the layer thickness, measured parallel to the axial surface, is constant are **similar**. Similar folds tend to have persistent profiles, that is, the folded outline including wavelength, symmetry and general shape of a given layer is repeated by all adjacent layers: the strata are bent into

Folds

jpb, 2017

similar curves. As a geometrical consequence, beds do not retain their original thickness throughout and the limbs are thinner than the hinges. Such folds do not die out upward or downward, but maintain the same curvature in the hinges. This is the case for kink folds, in particular.

In areas of intense folding there commonly are isolated, tight fold closures sandwiched between apparently unfolded foliation or layering surfaces; they die out upward and downward in otherwise unfolded rock; such structures are referred to as **intrafolial folds** or, if dismembered, as **rootless intrafolial folds**.

### *Flattened folds*

The concept of flattened folds is based on the idea that extreme shortening modifies the shape at high-amplitude buckle folds. Homogeneous flattening thickens the hinge regions, thins the limbs, and gradually reduces the interlimb angle. Estimates of flattening strain in Class 1C folds allow restoration of parallel fold shapes that in turn can be used to decipher the amount of shortening due to buckling. A simple and direct method to estimate flattening strain (the late-stage pure shear of buckling history) assumes that class 1C, 2 or 3 folds initially had a class 1B (concentric and parallel) shape. The estimate of buckle shortening, in turn, allows restoration of original length and thickness of undistorted beds, provided the layer-parallel shortening during the initial stages of folding is insignificant. Several techniques allow determining the amount of flattening, with the assumption that strain was homogeneous. However, none of these techniques considers the layer shortening that precedes buckling and therefore each gives a minimum bulk strain associated with the fold. An additional limitation is that all are two-dimensional.

*t' /  $\alpha$  method:* The amount of strain is determined from the way the orthogonal thickness  $t$  and the thickness parallel to the axial plane  $T$  of folded layers vary as a function of the limb dip.

*Inverse thickness method:* The thickness of the layer at any point around the fold is inversely proportional to the stretch (final length / original length) of the tangent to the folded layer at the angle of dip at which the thickness is measured. The technique is simple. (1) Measure the orthogonal thicknesses  $t$  perpendicular to tangents drawn to folded layer. (2) Plot inverse thicknesses  $1/t$  from a common point (i.e. in polar coordinates), each in the direction of the tangent line. A strain ellipse emerges that discloses strain due to flattening.

Strain from flattened buckle fold  
from Lisle (1992)  
*Journal of Structural Geology* 14(3)  
369-371

Folds in Precambrian gneisses (Gjeroy Island, Norway)

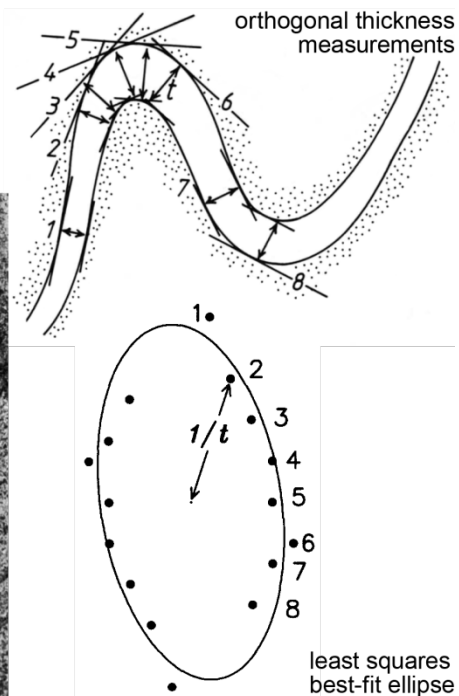

*Fold-center to median-layer-line distance:* The method is based on the assumption that, in concentric folds, the center to layer length in any direction is the diameter of an ellipse of the same aspect ratio as the strain ellipse.

- (1) On the fold profile, define the center as the intersection between the axial plane and the median line, which joins inflexion points.
- (2) Draw lines at regular angular spacing through the center.
- (3) Measure the distance  $d$  from the center to the middle of the folded layer along each line. Again, a strain ellipse emerges on a polar graph where  $d$  is plotted as a function of line orientation.

*Isogon rosette:* Dip isogons are drawn on the profile section of a fold by linking the points of equal dip on the inner and outer arcs. They can be arranged in a rosette by displacing the isogons without changing their orientation until the mid-point of each isogon becomes the common point of intersection of all isogons. The end points of isogons in the rosette trace a characteristic curve that defines the fold geometry. This curve is a circle in parallel folds, an ellipse in flattened parallel folds, and it reduces to a pair of points in “similar” folds. Since isogons deform as material lines during flattening, the characteristic curve, namely, the ellipse, directly represents the strain ellipse in flattened parallel folds. The “isogon rosette” method allows representation of a given fold by a point on the  $R_s - \theta$  plot, where  $R_s$  and  $\theta$  are the two-dimensional strain ratio and the angle between the maximum principal strain and the fold axial trace, respectively.

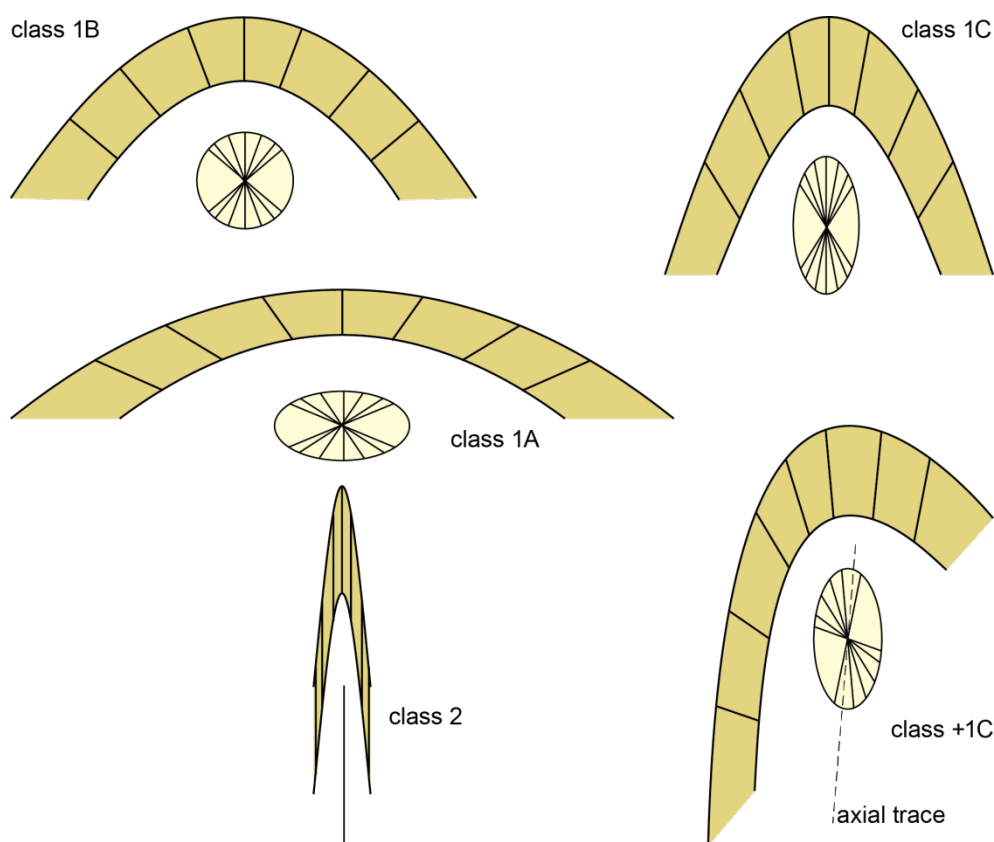

Profile sections with isogone in different classes of folds with characteristic curves through end points of isogon rosettes after Srivastava & Shah 2008 *Journal of Structural Geology*, 30, 44-450

### *Axial plane continuity - harmonic and disharmonic folds*

Folds in which axial planes are continuous across successive folded layers that show approximately the same wavelength and amplitude are **harmonic**. Typically, similar folds that ideally maintain their shape throughout a section are harmonic. Folds in which the amplitude, wavelength and style change along discontinuous axial surfaces from one layer to another are **disharmonic**. Disharmonic folds



develop because of differing rheology in the different layers. The incompetent beds are squeezed and adapt to the form imposed by the competent beds.



Disharmonic folds are particularly common in areas of parallel folds because they die out with increasing depth along their axial plane, reaching over-tightening in the core. Consequently their extent is limited to the centre of curvature beyond which shortening should be accommodated by faulting or another type of folding. They may terminate downward at some surface, called **detachment** or **décollement**, along which they are separated (decoupled) from unfolded layers below. The Jura Mountains are typically cited for such relationships.

### Symmetry

Folds are **symmetrical** if the axial plane bisects the interlimb angle and divides the fold in two identical halves. In symmetrical folds with a vertical axial plane the hinge line passes through the crest and trough of antiforms and synforms, respectively.

If the axial plane is not a plane of symmetry, the limbs have unequal lengths and one limb dips more steeply than the other: the folds are **asymmetrical**. Their leaning direction suggests a relative sense of movement, termed the **apparent vergence**.

### **Fore limb - Back limb**

An asymmetric or overturned antiform has a steep and short **forelimb** and a gentler, longer **back limb**. The forelimb is stratigraphically inverted in overfold anticlines. This forelimb is **reversed**, or **inverted** or **overturned**, whilst the back limb is **normal**. Note that the overturned limb dips steeper, and the normal limb shallower than the axial plane. Note also that inverted bedding youngs in the opposite direction to which it dips.

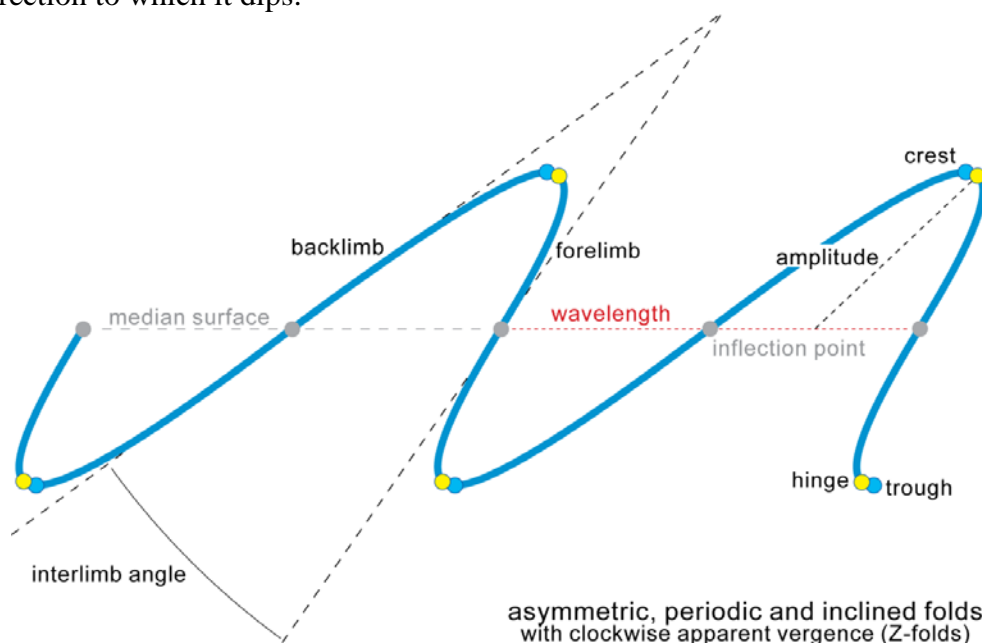

### Facing and vergence

The direction of apparent movement of the upper, long limb with respect to the shorter limb of an asymmetric fold is called the vergence. In other word, vergence is simply the sense of asymmetry. The true vergence or facing is the younging direction along the axial plane in a direction perpendicular to the fold axis. Uniformly verging asymmetric folds are characteristic of thrust belts. Vergence is useful in working out the regional direction of transport and help to fix an observation location on large folds.

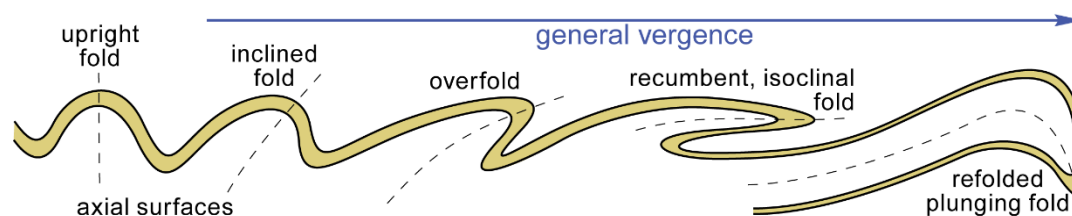

Antiformal synclines and synformal anticlines are **downward facing folds** since the stratigraphy is completely inverted in passing along the axial plane; conversely, anticlines and synclines are **upward facing folds**. Downward facing folds are commonly formed during refolding of the stratigraphically inverted limb of a recumbent fold.

Attention: in the German literature the term has been applied to the direction toward which the fold is leaning, with the idea that the form of the fold profile represents the frozen movement and rotation that generated this fold form. The **movement picture** is supposable where all folds express a unique one-sided regional movement. However, the asymmetry of subsidiary folds varies from one limb of a large fold to the other limb (see paragraph on parasitic folds, below). Strictly speaking, the form of a fold should be defined as an apparent vergence by opposition to the true vergence that includes the younging direction. The true vergence of first order folds then defines the movement picture.

### Fold trains

A **fold train** is a series of folds along a particular layer or series of layers.

Several folds may develop next to each other within a soft layer between virtually unfolded competent layers. When such layer-bounded fold trains display a systematic vergence, the sense of fold asymmetry affords a bulk relative sense of layer-parallel shear. Such folds are called **drag folds**, the implication being that the shear component of the velocity gradient across the layers has dragged the soft layer into a suite of folds characteristically non-cylindrical, asymmetric and disharmonic (i.e. the soft layer becomes detached from the adjacent layers). In the same way, drag folds may also develop within a thrust zone.

Gravitational forces acting on plastically deforming layers can produce **cascades** of folds.

### Parasitic folds

Hinge zones and limbs of large folds often display folds of smaller wavelength and amplitude: larger and smaller folds are together **polyharmonic**. The small folds are called **parasitic** or **subsidiary folds** with respect to the larger ones. The largest folds are termed **first-order folds**, the next largest are called **second-order folds** and so forth.

The axes of parasitic folds are habitually closely parallel to the axis of the major fold with which they are associated. They are said to be **congruous**, by contrast with **incongruous** parasitic folds whose axes deviate appreciably from the attitude of the major fold axis.

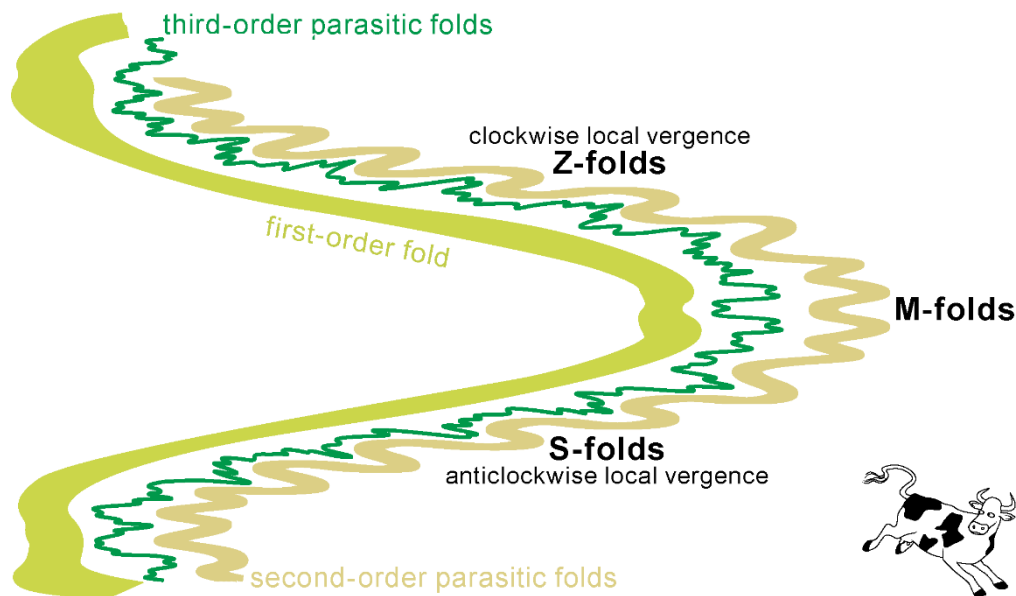

First-order folds may be symmetrical whereas the congruous, second-order folds are asymmetrical. The sense of asymmetry, referred to as **local apparent vergence**, is consistently towards the hinges of higher-order antiforms. It changes systematically across the axial surfaces of the first-order folds, so that, looking down the axial direction, all parasitic folds in a limb have a **clockwise** apparent vergence and are described as **Z folds**, whereas those in the other limb have **anticlockwise** apparent vergence and are **S folds**. Symmetrical **M folds** generally occur in the hinge zone (W may be used for synforms opposed to antiforms). The axial plane of the first order fold links and runs across second order M folds and separates limbs with S and Z second-order folds. In the field, the asymmetry is used to locate hinges of the next larger order folds if they were both generated together. Note that flexural slip and/or flow provides a coherent explanation of why Z and S second order folds form on the limbs of a first order fold. Parasitic folds would initiate as symmetric buckle folds sheared hingewards during flexural flow of incompetent layers.

### Enveloping and median surfaces

The average orientation of a folded surface affected by a fold train is measured from the **enveloping surface**, which is constructed either as tangential to most or all of the hinge zones in the folded surface. The enveloping surface defines the limits of folds, thus relates the geometry of small- to large-scale folds in areas where there are so many small-scale folds that they obscure the general orientation of bedding (e.g. in a tightly folded limb). Which folds are touched by the enveloping surface depends on the scale at which the structure is being considered.

The **median surface** joins the successive inflection lines of a folded surface. The median surface separates antiforms from synforms.

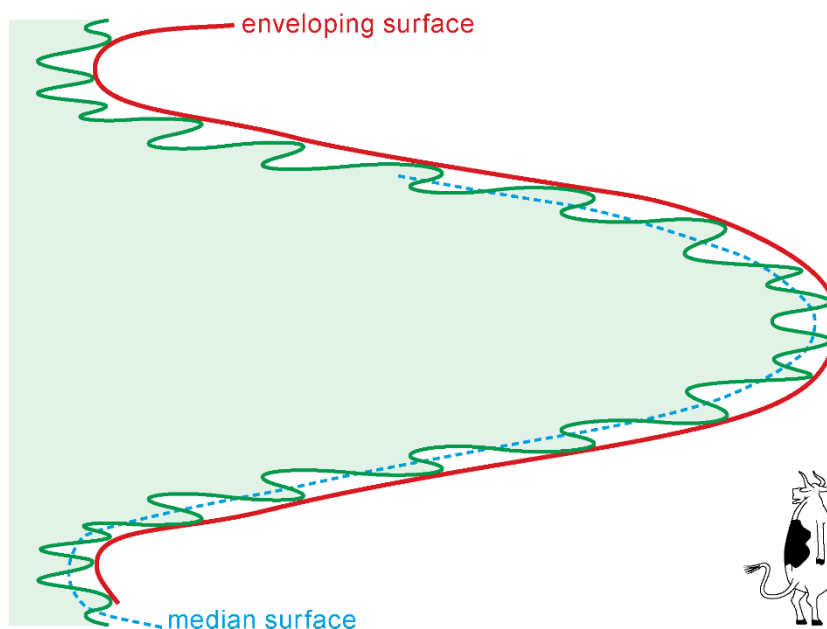

The median and enveloping surfaces are generally almost parallel and, therefore, yield the same information. Axial planes of symmetrical folds are perpendicular to the enveloping and median surfaces.

### Wavelength, arc length, amplitude and aspect ratio

Amplitude and wavelength define the **size** of a single fold and refer to the mathematical terminology used to describe a sinusoidal curve.

#### **Wavelength**

The distance between two successive anticlinal (or synclinal) hinges seen in profile is the **wavelength**. The distance between inflexion points can also be used to measure the wavelength. The **arc length** is the distance along the folded plane between two points separated by one wavelength.

#### **Amplitude**

The **amplitude** is measured by taking half the distance along the axial plane from one anticlinal hinge to the surface enveloping the two adjoining synclinal hinges (or vice versa), in other words, the distance along the axial plane from the median surface to the hinge. A train of folds may fold a surface periodically or non-periodically.

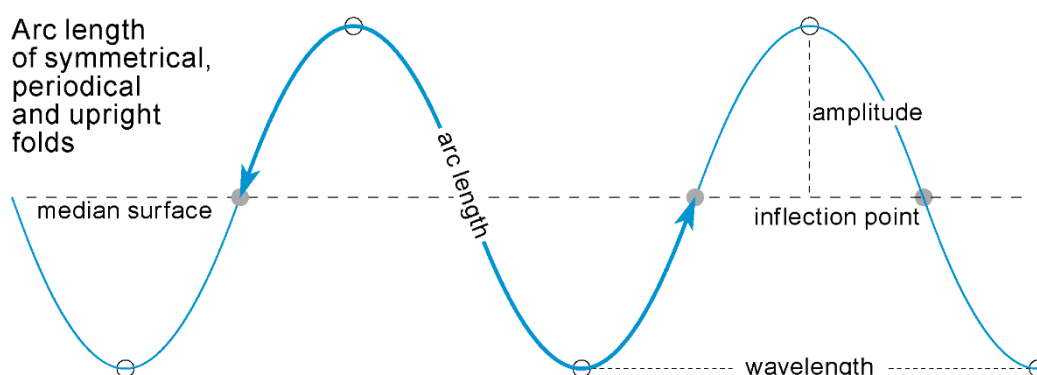

The term **pericline** is applied to large-scale antiforms or synforms whose amplitude decreases regularly to zero in both directions, so that the fold has precise limits in space. Domes and basins are periclinal structures.

### *Aspect ratio*

The ratio of the amplitude to half the wavelength is the **aspect ratio** of a fold.

Where folding is disharmonic, both wavelength and amplitude of folds vary between successive layers.

### Conjugate folds

The term **conjugate** is used to describe any pair of identical folds that have axial surfaces inclined at a high angle to one another in profile (resulting in opposite vergence) or in map view. Such folds generally terminate in an angular fold, or yet another orientation, at the point where their axial surfaces meet or intersect one another, in general in an incompetent layer.

Conjugate folds with round hinge zones are box folds. **Conjugate kink bands** (conjugate folds with angular hinges) are common.

### Collapse folds

In regions folded in near surface conditions, folds with rather flat-lying axial planes and a local vergence opposite to that of parasitic folds are due to gravity-driven collapse into the synclinal regions of layers first steepened by folding. **Flaps** are overturned sequences that result from bent over backward gravitational instabilities, without breaking.

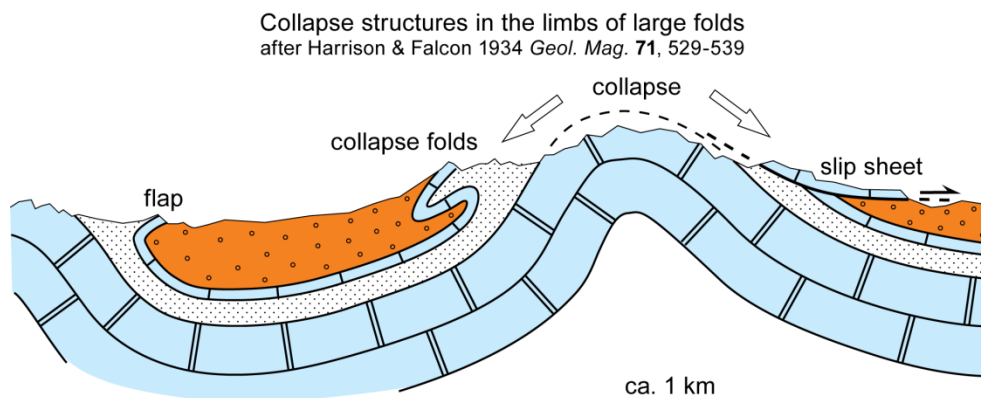

## **Morphological classification - Thickness variation of a folded layer**

Structural geologists have long used the shapes of folds for determining the amount of shortening due to folding in layered rocks. They have elaborated a range of techniques to estimate shortening from fold shapes.

### Geometrical parameters

The variable curvatures of hinge zones and limbs of successive surfaces reflect thickness variations of layers resulting from folding. These shape changes can be categorised in terms of three interdependent measurements on the profile:

$\alpha$  = dip angle at different points on successive folded surfaces;

$t_\alpha$  = layer thickness normal to layering where  $\alpha$  is measured;

$T_\alpha$  = layer thickness parallel to the axial plane where  $\alpha$  is measured.

These three measurements are the basis of a classification that refers to **dip isogon patterns**: A dip isogon is a line linking points of equal limb dip on the outer and inner arcs of a folded layer seen in profile section (i.e. seen orthogonal to the fold axis).

This classification involves an indirect relationship everywhere on the fold:

$$T_{\alpha} * \cos \alpha = t_{\alpha}$$

The thickness at the fold hinge is  $t_0 = T_0$ . The ratio  $t' = t_{\alpha} / t_0$  or  $T' = T_{\alpha} / T_0$  can be calculated and plotted versus the angle  $\alpha$ . This ratio expresses changes in orthogonal thickness with change in dip  $\alpha$ .

### Construction

Dip isogons are constructed as follows:

- Draw the trace of the axial plane on a profile view of the fold (i.e. orthogonal to the fold axis).
- Draw another line perpendicular to this trace, preferably out of the fold.
- With a protractor gliding along the line orthogonal to the axial plane, locate points along the folded surface whose tangents intersect the glide-line at specific angles.
- A set of iso-angle points on adjacent folded surfaces permits the drawing of dip isogons.

The orientations of the dip isogons over a fold qualitatively describe the variation in thickness and the difference of curvatures between successive interfaces. If isogons are convergent towards the core of the fold, the curvature of the outer arc is less than that of the inner arc. Conversely, if isogons are divergent towards the core of the fold, the curvature of the outer arc is greater than that of the inner arc.

### Fold types

The characteristics of the dip isogons leads to a three-fold classification, with two additional sub-classes: Class 1 folds with isogons convergent towards the core of the fold (curvature of the inner arc is greater than outer arc), class 2 folds with isogons parallel to the axial trace (curvature of the inner arc is equal to outer arc) and class 3 folds with divergent isogons (curvature of the inner arc is smaller than outer arc).

Class 1 is subdivided into three sub-classes according to the degree of convergence:

- class 1A are strongly convergent, meaning that thickness of folded layers in hinges are thinner than those in limbs.
- class 1B are a special case of parallel folds where the isogons are perpendicular to the fold surface.
- class 1C folds are weakly convergent, meaning that thicknesses of folded layers in hinges are thicker than those in limbs.

Class 2 folds are a special case of similar folds along which the curvature of successive folded surfaces remains the same.

Class 3 are folds where the curvature of successive folded surfaces decreases toward the inner arc of the fold.

These classes are shown on the  $t' / \alpha$  plot. This classification is purely geometric and tells nothing about folding processes.

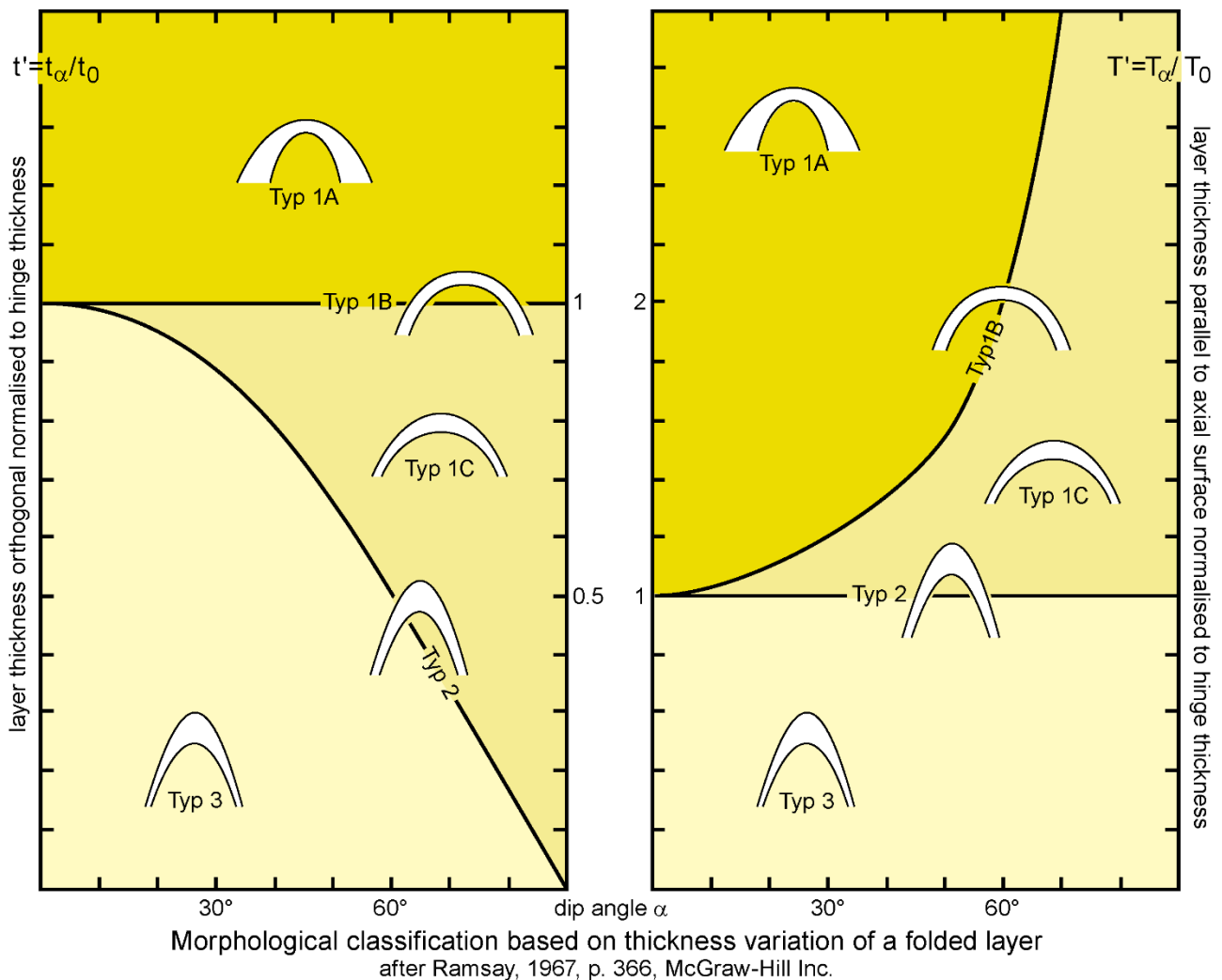

### Fault-related folds

There commonly are folds geometrically associated with faults. They are in general controlled by the fault geometry.

#### Drag folds

Bedding is frequently bent in fault zones. These local flexures are known as **drag folds** and **fault drags**. They usually are convex toward the direction of the fault movement and are thus attributed to some frictional resistance to slip along the fault plane. This interpretation suggests that faulting is initiated first and that folding occurs adjacent to the fault as one block is dragged along the other (normal drag). However, folding might precede faulting, drag folds representing bending of rock before it breaks.

#### Drag folds against fault planes

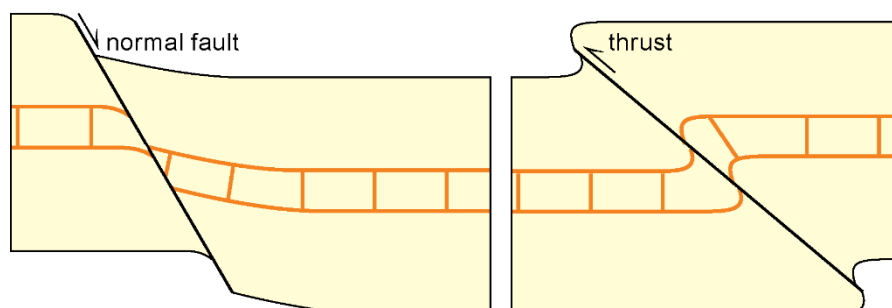

The use of drag folds, intuitively inferring that the direction of folding is toward the direction of fault movement, can be misleading because convexity opposite to the sense of displacement, termed **reverse drag**, is common. For example, roll-over flexures on listric normal faults are hanging wall folds concave towards the slip direction. Reverse drag is hardly distinguished from normal drag when they appear separately. In addition, the orientation of drag folds is often not controlled by the movement direction but rather the intersection between bedding and the fault plane, and the drag may vary from reverse to normal from the centre to the termination of faults. Therefore, drags should be used with extreme care to ascertain the sense of slip along faults.

Trains of drag folds are common in incompetent layers between two competent layers of in the proximity of thrust faults.

### *En échelon folds*

In some non-cylindrically folded surfaces, doubly plunging and relatively short, nearly upright folds in parallel series have alternating antiform and synform axes oblique to the fold string. Such folds are stepped and consistently overlapping; they define an *en échelon* array. Note, however, that this term describes the geometry of the folded surface and is independent of the relationship of the structure to the horizontal and vertical.

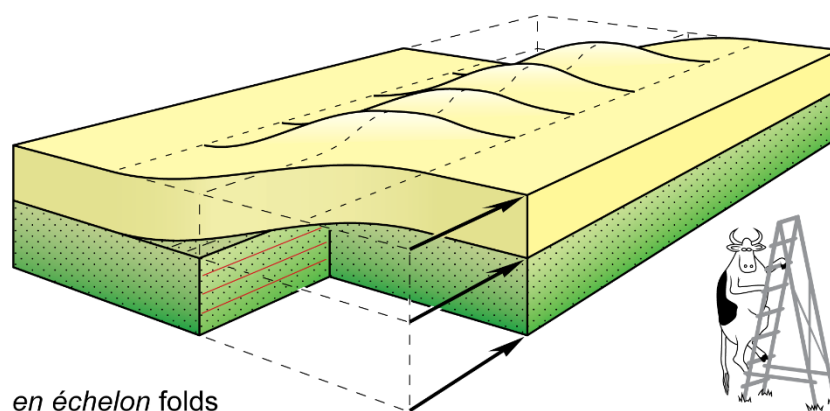

Taking the steep axial planes as roughly orthogonal to the shortening direction, their distribution permits to decipher the potential fault they are related to. Such folds are common above strike-slip faults that have not broken the cover but offset the basement blocks. The *en échelon* fold-pattern reveals the relative sense of movement along the basement fault.

### *Drape folds - Forced folds*

Cover rocks can be more or less passively bent to conform to the topography of the buried basement / cover interface. An important shape-controlling factor is whether the cover remains welded to or is detached from the basement.

**Drape folds** are generally open curvatures in a sedimentary layer that conforms passively to the configuration of underlying structures and geological bodies. A fold formed by differential compaction is an example.

**Forced folds** are generally fault-related, long and linear flexures that relative movements of basement blocks generate in cover rocks. Their overall shape and trend are dominated by the shape and trend of the underlying forcing fault blocks. They are typically monoclines with long, gently-dipping backlimbs and short, steeply-dipping forelimbs, the latter overlying the fault surface. They are equally common in compression and extension regimes. The type and amount of fault movement controls the fold profile geometry.



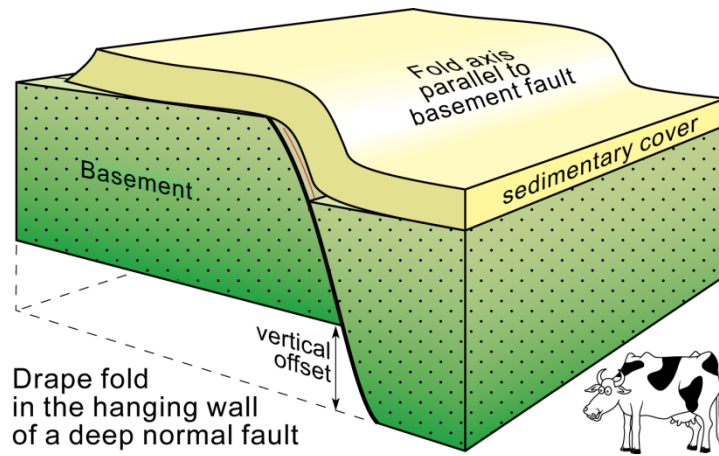

### Thrust-related folds

Thrust movement at depth generates geometrically necessary folds in the allochthonous hanging-wall as it moves over topographic irregularities of the thrust faults. Kink-like, box folds result. Two types of ramp-related folds are common in thrusts belts.

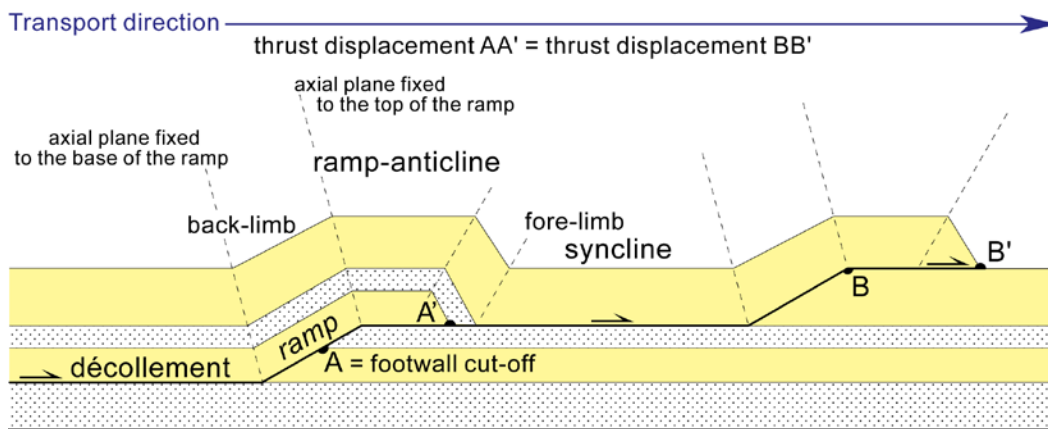

Passive folding of the hanging-wall of a flat-and-ramp thrust system

- **Fault bend folds** form and grow above a footwall ramp where a fault steps from a lower flat to a higher one and strata of the hanging wall slide over the fault bend. As slip occurs, the hangingwall is folded to accommodate to the shape of the footwall ramps in a passive syncline-anticline pair at the base and top of the ramp. Specific geometries are maintained throughout the development of the anticline. (i) The ramp anticline terminates downward into the upper-flat. (ii) The backlimb is parallel to the footwall ramp. (iii) The forelimb is shorter and steeper than the backlimb. (iv) the anticline-syncline pair directly reflects the geometry of the fault bends.

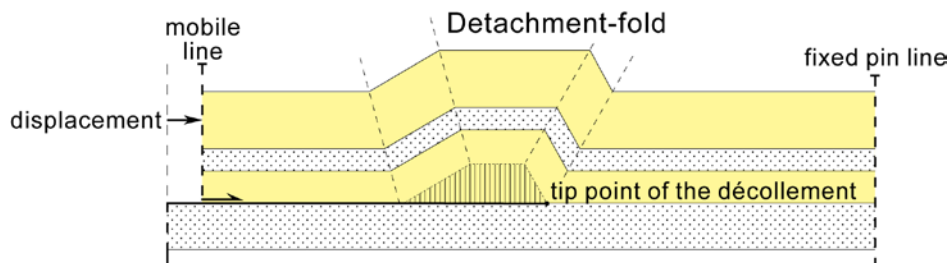

- In a **fault-propagation fold** the ramp does not continue to an upper flat. Strata cut by the base of the ramp are shortened by thrusting. Fault slip decreases to zero in the up-section direction and the fault dies out into the axial surface of a syncline. Strata above and in advance of the upper tip line of the propagating thrust are shortened entirely by folding. Typically (i) such folds are asymmetric in

the direction of thrust movement, (ii) they tighten with increasing displacement, and (iii) both limbs lengthen while the fault tip propagates upwards.

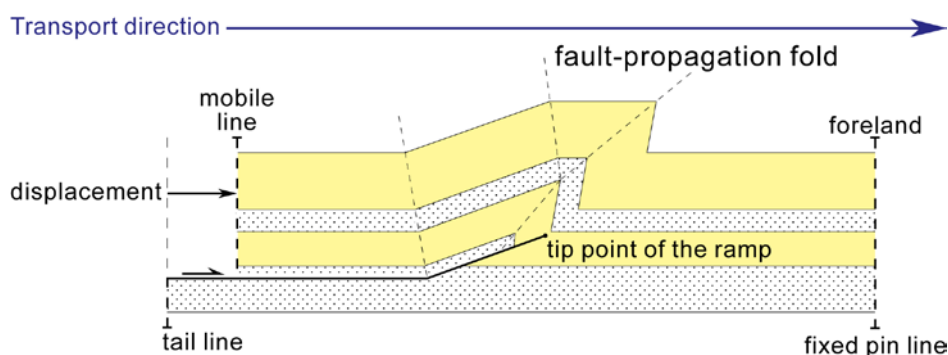

- **Growth folds** develop in sedimentary strata at the same time as they are being deposited. Antiformal structures commonly grow over a ramp or a duplex zone to build **antiformal stacks**.

The common association of folds and thrusts at a regional scale defines a **fold and thrust belt**. The fold shape is determined by the shape of an advancing ramp that does not tie into an upper flat. The ramp fault is replaced upward by an asymmetric fold, which is overturned in the direction of transport. There is a systematic and predictable geometric relation between a fold and the thrust that generated it, and we can therefore use fold geometry to infer fault position and geometry at depth.

### Normal-fault-related folds

As in thrust systems, geometrically necessary folds are generated above topographic irregularities of extensional faults. Tilting of the hanging wall of a normal listric fault toward the main fault produces a half-antiform called rollover anticline. The rollover anticline is a gentle convex bending of upper-block beds necessary to accommodate the concavity of a listric normal fault. As the hanging-wall slips along the deep, gently dipping parts of the fault, an additional volume is generated between the footwall and the hanging wall along the shallower, steeper parts of the fault. Beds initially horizontal in the hanging wall must become gently convex upwards to fill up this additional space.

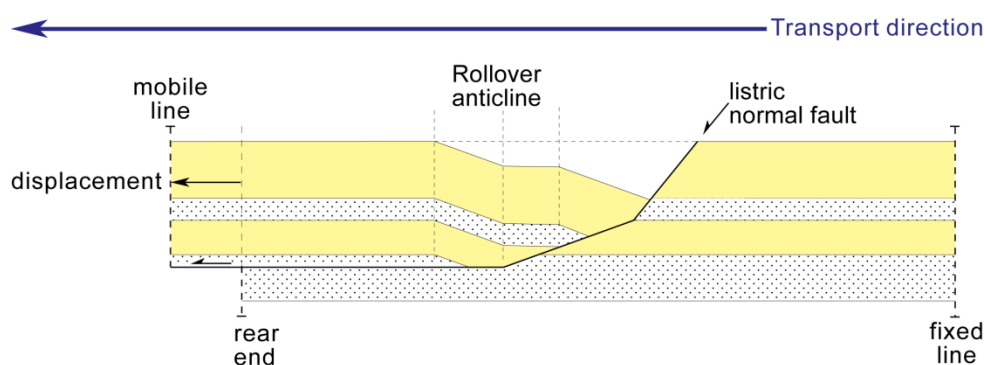

Listric fault associated with an antithetic flexure (roll-over)

### Tear faults

In areas like the Jura, strike-slip faults seem to tear the folds across. They are attributed to differential advance of adjoining segments of the folds, with folds in one block being more closed and tighter than in the other. Tear-faults as such are transfer faults that originated during folding.

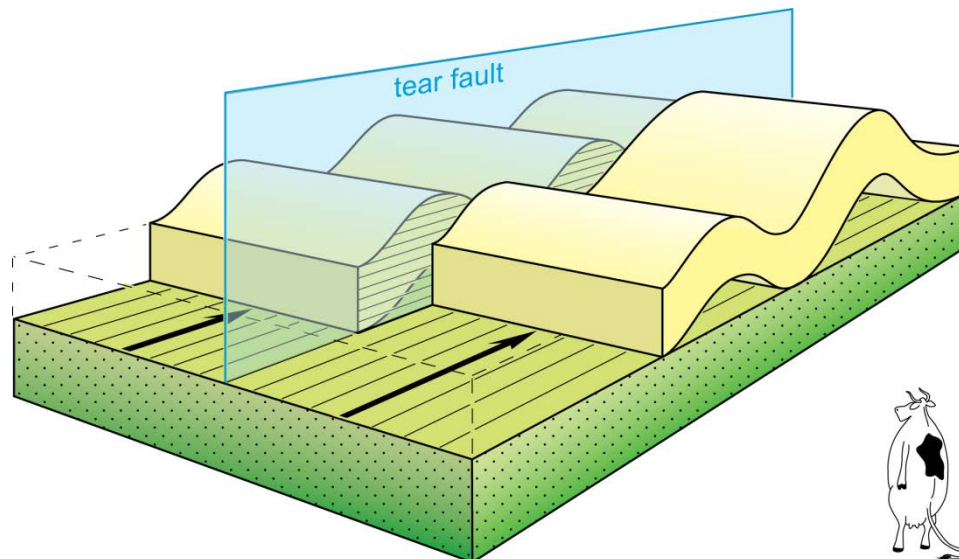

### Fracture patterns in folds

Geometry and density of fractures accommodate the strain induced in the strata during folding. Fracture sets are commonly documented to vary from hinge to limb.

- In hinge regions fractures are mostly parallel to the fold axis and orthogonal to bedding. Joints and normal faults are formed by curvature-related, extensional stresses within the outer-arc of the fold. Stylolitic joints and thrusts are formed by compressional stresses within the inner-arc of the fold.
- In limbs fractures are mostly parallel to the fold axis but oblique to bedding. They are related to interbed slip.

### Primary folds

Lavas commonly develop surface folds during flow. These folds are due to the different properties of the chilled outer crust of the lava relative to the hot, faster flowing inner part.

In magmatic rocks, folds often deform the primary banding during the late-stage flow of the magma. Non-lithified sediments are considered to be suspensions that can deform in a ductile manner. Gravity-driven sliding (slumping) of unconsolidated layers therefore often produces complex fold shapes called in short slumps. Slumped layers typically lay between undeformed strata.

### Determining a shear direction from fold orientations

Layers in sheared rocks commonly form non-cylindrical drag-folds whose axial planes are near the shear plane, sheath folds being one end member of this geometry. The hinges are curved because their orientation depends on several parameters such as the original orientation of the layer relative to the shear plane and local heterogeneities of flow. Furthermore, fold hinges can form parallel to the shear direction, or can rotate towards the shear direction during progressive deformation. Therefore, fold hinges are rarely orthogonal to the slip direction. Because of such important local changes, isolated small scale folds alone frequently give misleading transport directions.

A safe assumption is that the asymmetry of any fold pertaining to the same set is consistent with the sense of shear that produced them. This consistency is the basis of the geometric method that provides a guide to the slip direction. The (Hansen) method considers a group of minor folds and proceeds as follows:

- 1) All hinge orientations are plotted on a stereonet with their individual sense of asymmetry.
- 2) All hinges should lie approximately on the same axial plane (e.g. a great circle), near the shear plane.
- 3) The separation arc of the great circle across which the sense of asymmetry becomes opposite contains the slip direction, approximately along the bisector of the angle defining this arc.
- 4) The asymmetry of folds defines the bulk sense of shear.

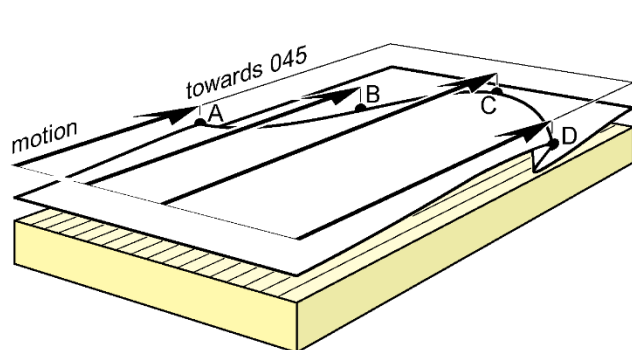

Kinematic interpretation  
of non-cylindrical folds

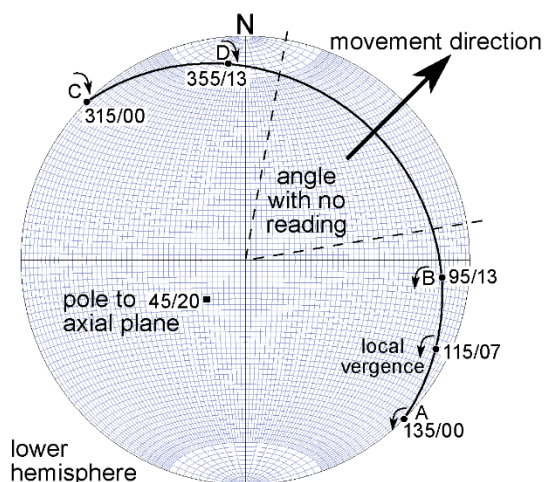

lower  
hemisphere

## Conclusion

A fold is a bend in a layered rock caused by compressive stress (buckling) or passive draping of layers over a lower structure or around a resistant object. Folds represent large-scale flow of material.

Folds display a wide range of shapes and result from a wide range of processes that both largely reflect the rock behaviour. It is therefore common to observe that geometrical characteristics change within the same fold from layer to layer.

Antiforms are hydrocarbon reservoirs. Folds host ore deposits in hinge areas due to flow of material to those localities. Folds form associated with faults and thus can signal earthquake hazards. Folds record periods of rock deformation, therefore generations need to be distinguished and dated. For these reasons, structural geologists have to document the fold geometry for economic and geologic hazard applications, the layer configuration as clues to conditions of deformation and the definition of fold generations for geologic history.

## Recommended literature

Hansen E. - 1971. *Strain facies*, Minerals, Rocks and Inorganic Materials. Springer-Verlag, Berlin, 208 p.

Ramsay J.G. & Huber M.I. - 1987. *The techniques of modern structural geology - Volume 2 : Folds and fractures*. Academic Press, London, 700 p.

Ramsay J.G. - 1989. Fold and fault geometry in the Western Helvetic nappes of Switzerland and France and its implication for the evolution of the arc of the Western Alps, in: Coward M.P., Dietrich D. & Park R.G. (Eds.), *Alpine Tectonics*. Blackwell Scientific Publications Oxford, Geological Society of London, Special Publications **45**, pp. 33-45.

Reches Z. & Eidelman A. - 1995. Drag along faults. *Tectonophysics* **247** (1-4), 145-156.

Treagus J.E. & Treagus S.H. - 1981. Folds and the strain ellipsoid: a general model. *Journal of Structural Geology* **3** (1), 1-17.