

Designing a manual press for blackwater dewatering

Bachelor Thesis

Author(s):

Hugentobler, Magnus

Publication date:

2023-11-27

Permanent link:

<https://doi.org/10.3929/ethz-b-000653369>

Rights / license:

[Creative Commons Attribution 4.0 International](#)

eawag
aquatic research ooo

ETH zürich

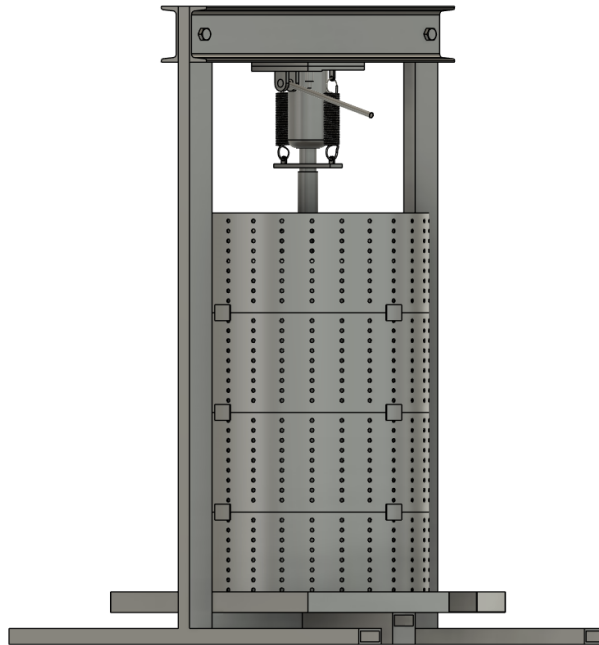

Designing a manual press for blackwater dewatering

Bachelor thesis, D-MAVT

Author: Magnus Hugentobler

ETH supervisor: Prof. Dr. Elizabeth Tilley

Co-supervisor: Dr. Linda Strande

Examinors: Dr. Jakub Tkaczuk

Michael Vogel

November 27, 2023

ACKNOWLEDGEMENTS

I want to thank my supervisor, Michael Vogel, for his assistance, and valuable and constructive feedback throughout my bachelor's thesis.

I'd also like to thank Dr. Jakub Tkaczuk for his thorough feedback on my report before submission.

CONTENTS

List of Tables	vii
List of Figures	ix
Abstract	xi
1 Introduction	1
1.1 Background	1
1.2 Goal of thesis	2
2 Methods	3
2.1 Approach	3
2.2 Concept Selection	3
2.3 Tools	5
2.4 Constraints	5
2.4.1 Fecal Sludge Production	5
2.4.2 Localization	5
2.4.3 Material	6
2.4.4 Manufacturing	6
3 Results and discussion	7
3.1 Operation of the press	7
3.2 Design 1	8
3.2.1 Pressure Mechanism	8
3.2.2 Frame	9
3.2.3 Basket	10
3.2.4 Conclusions for design 1	10
3.3 Design 2	11
3.3.1 Design changes	11
3.3.2 Pressure Mechanism	11

3.3.3	Frame	12
3.3.4	Basket	13
3.3.5	Filters	13
3.3.6	Conclusions for design 2	13
3.4	Discussion	15
4	Conclusion	17
	Bibliography	19
	Appendix A - Calculations	21
A.1	Fecal Sludge accumulation	21
A.2	Screw connections	21
A.2.1	Vertical press	21
A.2.2	Horizontal Press	22
A.3	Spindle	23
A.4	Stress	24

LIST OF TABLES

- 2.1 Goals and allocated time for the sprints and concept selection. 3
- 2.2 Ratings of concepts based on weighted criteria. The scale goes from 1 (bad) to 5 (good). 4
- 3.1 Quantitative comparison of Design 1 and Design 2. * = low, ** = medium, *** = high. 15

LIST OF FIGURES

- 1.1 A Settling-thickening tank and Drying bed. (Source Velkushanova *et al.* (2021)) 1
- 2.1 Sketches of pressure systems before selection 4
- 3.1 Exemplary filling and dewatering procedure of design 1. 7
- 3.2 Mockup of hydraulic jack with springs (a) and stacking piece to extend the hydraulic jack (b). 8
- 3.3 Drawings of design 1. All numbers are in mm. 9
- 3.4 Spindle of design 2 with press head 11
- 3.5 Design 2 with the different pressure mechanisms. Both the spindle and support rods of the hydraulic jack are fully inserted. All numbers are in mm. 12
- A.1 Top beam of vertical press simplified to beam with pinned ends. 21
- A.2 Fatigue strength diagram with the associated load case to determine the maximum bending moment. (Source: Wittel, Spura, and Jannasch (2021)) 25
- A.3 FEM of Design 2 25
- A.4 FEM-analysis of a beam from design two. Highlighted are the two most significant stresses of the beam. 25

ABSTRACT

Most of sub-Saharan Africa relies on non-sewered sanitation. In the treatment of the accumulating blackwater dewatering is a crucial step. Established technologies for dewatering are drying beds or settling tanks. These methods are often land- and time-intensive. Mechanical dewatering offers a solution to this problem. However commercially available mechanical dewatering presses are often too big in scale, require electricity for operation, and rely on the global supply chain. Therefore two designs of a manual mechanical dewatering press that serves a small-scale, urban community of 5000 people were conceived. These presses are constructed with widely available construction steel, which allows for their construction in local workshops. The pressure mechanism in both designs is powered by a widely available 12 t hydraulic car jack. The major difference between the two designs is the orientation, one is vertical the other horizontal.

In a comparison between the vertical and horizontal design, the vertical design emerged with more advantages. These advantages were mainly from cheaper manufacturing, easier assembly, and knowledge of the workings of the system due to tests with smaller-scale fruit presses that employ a very similar concept. Because of the aforementioned reasons, the vertical system is recommended for construction. If a horizontal system is desired a change of concept to a filter press is suggested.

1 INTRODUCTION

1.1 Background

Nearly 3 billion people rely on non-sewered sanitation. Especially in sub-Saharan Africa most of the sanitation needs of urban areas are covered by on-site technologies (Strande, Ronteltap, and Brdjanovic, 2014). Fecal sludge is what accumulates in these on-site technologies. It is composed of blackwater (human excreta and additional inputs such as flushwater, menstrual hygiene products, and toilet paper) and possibly other wastewater streams such as greywater and solid waste (Velkushanova *et al.*, 2021). Contrary to wastewater it is not transported by sewer but instead stored onsite and periodically collected. While most of the population's sanitation needs are met through onsite technologies, the necessary systems to treat the accumulating fecal sludge are often not in place (Velkushanova *et al.*, 2021; Strande, Ronteltap, and Brdjanovic, 2014). With the consequence that the collected fecal sludge often gets dumped into waterways, landfills, or poorly designed pits (Peal *et al.*, 2014).

If the fecal sludge makes it to the treatment plant dewatering is one of the most important steps, as the separation of the liquid and solid parts is a must before either part can be treated further and disposed of. Settling-thickening tanks, and drying beds, like in Figure 1.1 are the most common and established technologies for dewatering. However, these technologies have



(a) Settling-thickening tanks

(b) Drying beds

Figure 1.1. A Settling-thickening tank and Drying bed. (Source Velkushanova *et al.* (2021))

the drawback of high land usage and long residence times to adequately dewater fecal sludge. Due to these factors, mechanical dewatering presses are considered to increase throughput and performance and decrease footprint (Velkushanova *et al.*, 2021).

Commercial mechanical dewatering solutions exist in various shapes and sizes and are often applied in the treatment of municipal wastewater or other industries such as mining. However, these are often designed to serve the demand of entire cities and are therefore too big for a small community scale. Additionally, these technologies require constant electricity supply, depend on the global supply chain for replacement parts, and are costly acquisitions. If there is a failure of parts, the downtime of these solutions is high or they might not even be able to be repaired. Consequently, in case of parts failure, the resulting downtime for these solutions is considerable, and in some instances, repair might not even be feasible. Therefore locally manufactured, manually operated dewatering presses are expected to circumvent these problems.

1.2 Goal of thesis

The goal of this bachelor thesis is to design a manual dewatering press for non-sewered sanitation. The dewatering press will be operated in an urban setting of bigger cities in sub-Saharan Africa. The press should be able to dewater the fecal sludge of a community of around 5000 people in one workday. Additionally, the press should be made out of low-cost materials sourced locally, enabling construction in local workshops to ensure independence from the delays of the global supply chain and the electricity grid.

2 METHODS

This chapter describes the approach and methods used while designing a manual dewatering press. It also defines the constraints set by the goals of the thesis on the press design.

2.1 Approach

The thesis starts by exploring and finding a fitting concept for the mechanical dewatering press. Then, different concepts are compared with weighted criteria. The best concept is chosen for the design phase, which in turn is inspired by agile product development. Many aspects of the agile methodology were implemented but not the production and physical testing of a design. It was decided against the physical production of a design due to the time restrictions of the bachelor's thesis and the fear of supply constraints.

Agile product development is split into sprints - short, often intense work blocks with a review at the end. Each sprint ends with a meeting to discuss the current design and the suggested improvements for the next sprint ([Gastadello, 2021](#)). The goals and allocated time for the sprints and concept selection are found in [Table 2.1](#).

Table 2.1. Goals and allocated time for the sprints and concept selection.

Phase	Goals	Time allocation (No. of Weeks)
Concepts	Find suitable concepts for dewatering mechanism	1.5
Sprint 1	Design of press with hydraulic jack	2
Sprint 2	Design of horizontal press	2
Tweaks	Implement feedback of sprint 2	1

2.2 Concept Selection

The first step in selecting a suitable concept was to divide the system into sub-systems. Each of these sub-systems has its own function. These sub-systems are: **Pressure system**, **basket** and **collector**. The shape and size of the collector strongly depend on the implementation

of the basket and pressure system, so no concepts were developed beforehand; instead, it is adapted to the other subsystems. The concept for the basket was quickly identified. Many commercially available fruit presses, which served as inspiration for several designs, utilize a cylindrical basket made of sheet metal with holes in the lateral surface. Therefore this concept was carried over into the initial sprint.

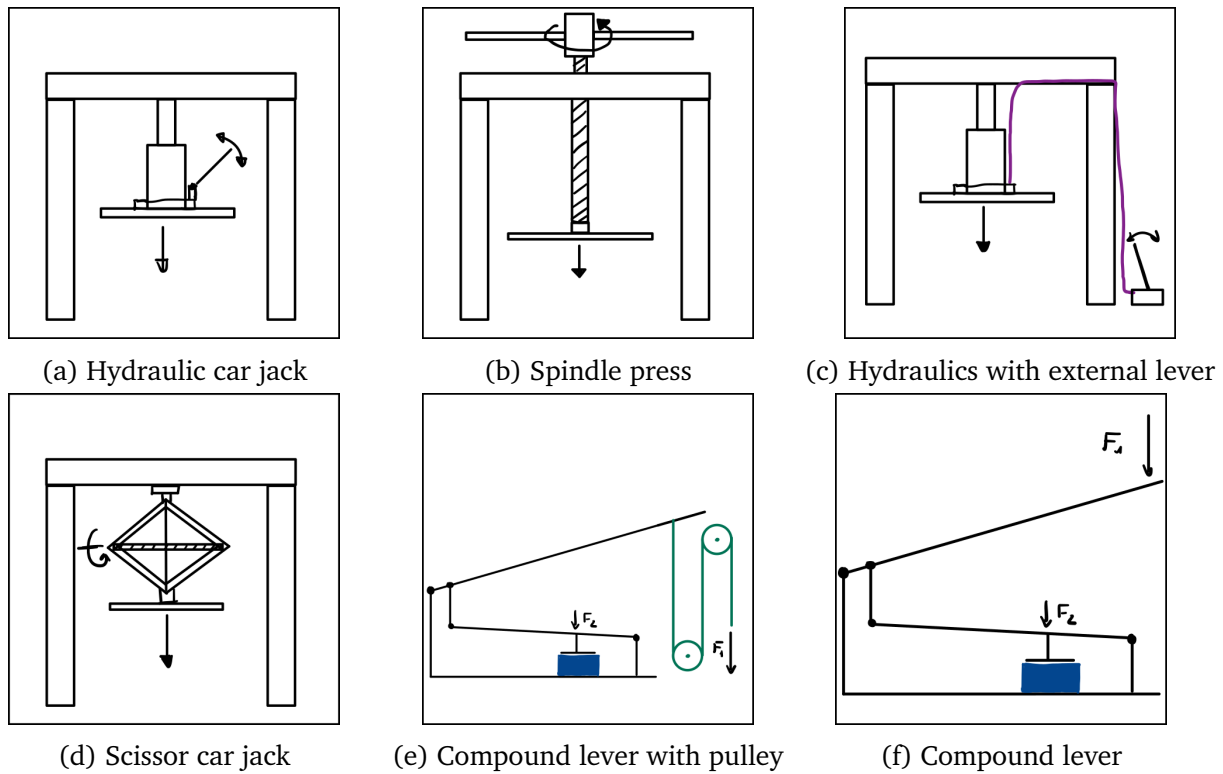

Figure 2.1. Sketches of pressure systems before selection

As a result, the pressure system was the only system where multiple different concepts were explored. These concepts can be found in Fig. 2.1. All these concepts were assessed using weighted criteria. Each concept was rated on a scale of 1-5 based on its expected performance in each criterion. The weights of the criteria were determined through binary comparison. The ranking and scores of these concepts can be found in table. 2.2.

Table 2.2. Ratings of concepts based on weighted criteria. The scale goes from 1 (bad) to 5 (good).

Criteria	Weight	Hydraulic car jack	Spindle	Hydraulics with external lever	Manual carjack	Compound lever with pulley	Compound lever
Manufacturing	0.17	5	5	4	5	3	5
Cost	0.23	3	3	3	4	4	4
Robustness	0.2	3	5	3	4	3	4
Pressure	0.17	5	4	5	2	4	3
Ease of use	0.23	5	4	5	4	4	2
Final Points		<u>4.14</u>	<u>4.14</u>	3.97	3.83	3.63	3.54

The standout concepts are the hydraulic car jack and the spindle press. The concept of the hydraulic car jack was carried over to the first sprint. This decision was prompted by the hydraulic jack's wide availability, eliminating the need for production, unlike the spindle.

2.3 Tools

To draw all the CAD models, Fusion360 was used. In addition, the integrated FEM-analysis tool was also utilized to check the structural integrity of the designs. [Wittel, Spura, and Janasch \(2021\)](#) was utilized to identify suitable materials for the press and to verify the integrity of the screw connections.

2.4 Constraints

This section explains the constraints set by the task description (Sec. 1.2) in greater detail.

2.4.1 Fecal Sludge Production

For the needs of this thesis, a small community was defined as one with at most 5000 inhabitants. The press needs to dewater the fecal sludge of such a community in one working day. According to [Velkushanova et al. \(2021\)](#) the per capita production of one person in Kampala (Uganda) is $270 - 280 \frac{\text{L}}{\text{cap}\cdot\text{year}}$, what translates to $3835.6 \frac{\text{L}}{\text{day}}$ for 5000 people (assuming $280 \frac{\text{L}}{\text{cap}\cdot\text{year}}$).

To estimate the amount of solids accumulating after dewatering, a simple mass balance is calculated. For the total solid content of the fecal sludge, 3.5 % was used ([Strande, Ronteltap, and Brdjanovic, 2014](#)). For detailed calculations see app. A.1. After dewatering 3836.6 L of fecal sludge, 604.1 kg of wet cake solids are left with the assumption of a total solids content of 20 %. With the 7 batches from sec. 3.2.1 each one has a cake weight of 86 kg.

2.4.2 Localization

This press is intended to be utilized and manufactured in urban regions of sub-Saharan countries, with a special focus on Freetown, Sierra Leone where information about local manufacturing workshops was obtained via communication with a local contact. The focus on Sierra Leone was chosen because its situation is exemplary for other sub-Saharan countries. It is one of the poorest countries in the world, most sanitary needs are met by non-sewered sanitation and has low funding for such projects.

2.4.3 Material

Availability of material and cost plays a big role in the design process and thus, the construction materials need to be chosen accordingly. Therefore, structural steel S235 was selected as the material for the frame for the reason of costs and availability (Wittel, Spura, and Jannasch, 2021). Its main drawback is the low yield strength compared to only slightly pricier types of construction steel. However, this was a conscious decision to not rely on a higher-strength steel and to make the design applicable in more settings. A corrosion-resistant coating needs to be applied to counter the effects of using structural, and not stainless, steel as the press is subjected to a wet environment. If the selected steel is not available, any weldable steel, with similar or better yield strength is suitable.

Preferably, the basket and collector are constructed from stainless steel sheets due to their exposure to significant moisture levels and the resulting risk of corrosion.

In Freetown, Sierra Leone, various forms of steel are available for workshops, such as sheet metal and steel beams of different shapes. Additionally, hydraulic jacks are also confirmed to be available on the market (William, 2023).

2.4.4 Manufacturing

The local workshops are expected to have basic manufacturing equipment such as drills, saws, and lathes. Additionally welding equipment and tools to bend and cut sheet metal are available too. However, not all workshops might have all the necessary tools, so parts might need to be sourced from various places (William, 2023).

3 RESULTS AND DISCUSSION

3.1 Operation of the press

The horizontal and vertical designs follow a similar operational procedure. However, the design with the spindle excludes the step of adding stacking pieces. The process is initiated by securely placing the filtration bag within the basket (3.1a). Subsequently, fecal sludge mixed with flocculant is filled into the bag (3.1b). Throughout the filling process, a significant amount of liquid naturally drains out without mechanical assistance (3.1c). Filling may pause temporarily until some water has drained. Steps (b) and (c) get repeated until no more fecal sludge drains out of the basket (3.1d).

In the case of the vertical press, the bag's edges are folded in (3.1d), and a pressure plate is placed on top, ensuring complete coverage of the bag's opening. The bag in the horizontal press is sealed using a clip, latch, or knot to prevent unfiltered water from escaping.

Afterwards, the dewatering with mechanical assistance starts. The hydraulic jack extends until its hydraulic cylinder reaches full extension (3.1e). The hydraulic cylinder then gets retracted and a stacking piece is placed between the pressure plate and the car jack. The cylinder then gets extended again. This procedure is repeated till the force limit of the hydraulic jack is reached (3.1f).

This concludes the operation of the hydraulic jack. The stacking pieces and the press plate are removed from the basket. The only thing remaining is the dewatered sludge cake.

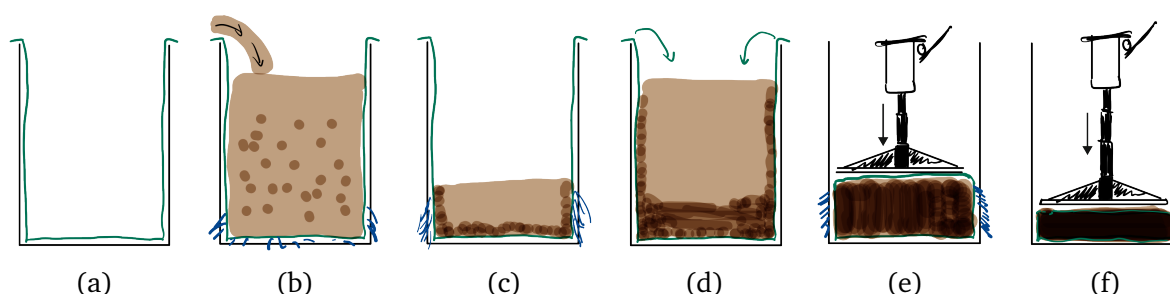

Figure 3.1. Exemplary filling and dewatering procedure of design 1.

3.2 Design 1

After establishing the constraint in manufacturing of the mechanical dewatering press in sec. 2.4. The first design of the press was developed. The goal is to use as many off-the-shelf parts such as C- & I-beams, plates, or metal sheets. This reduces assembly time and ensures a short replacement time.

3.2.1 Pressure Mechanism

As the objective is to dewater 3800 L of FS within a 7-hour workday, a batch size of 550 L was chosen. This yields a processing time of 1 h per batch. Assuming half of the volume drains out of the basket before pressing, the desired basket volume is 275 L. Commercial low-pressure dewatering presses typically operate at pressures ranging from 4-7 bar (Albertson *et al.*, 1987). The pressure the press plate ideally applies to the basket's contents is determined by:

$$p = \frac{F}{A} \quad (3.1)$$

Where F is the force of the hydraulic jack and A is the area of the press plate. With a force of 118 kN and a diameter of 0.6 m a 12 t hydraulic car jack produces a pressure of 4.16 bar. Which places it at the lower end of the desired pressure range. With a diameter of 0.6 m, the basket therefore has a height of 1 m to accommodate the desired 275 L of fecal sludge.

The reference hydraulic jack has a travel of only 140 mm, significantly less than the required 1000 mm. Therefore, extender pieces are necessary. In the first design, these are round 52 mm diameter steel poles with 140 mm height such as in fig. 3.2b. However, adjustments in both height and diameter are needed to suit the travel of the actually used hydraulic jack.

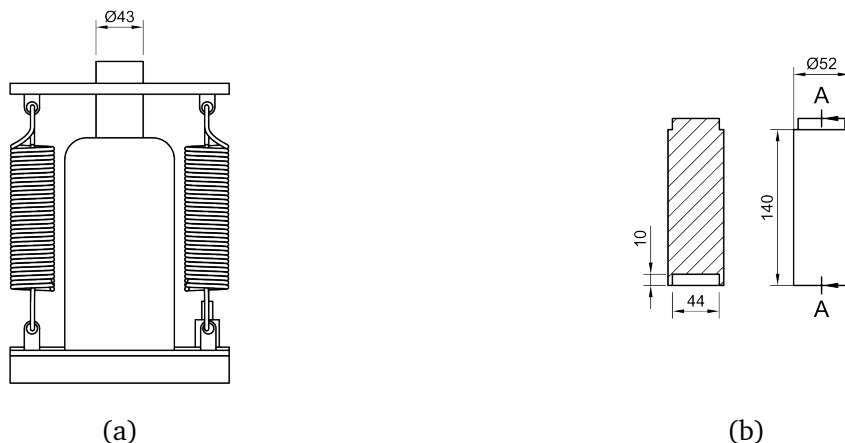

Figure 3.2. Mockup of hydraulic jack with springs (a) and stacking piece to extend the hydraulic jack (b).

To simplify the return of the car jack, two springs are connected to the end of the hydraulic cylinder such as in fig. 3.2a. However, the strength of these springs is not specified since the return force depends on the type of hydraulic jack used, and this information is not provided. Concerning mounting the hydraulic jack no detail was incorporated into the design as no specific hydraulic jack model was used. Due to varying geometry between models, details need to be determined on the used model. Ideally, the hydraulic jack gets mounted using screws, this ensures easier removal if maintenance is required.

3.2.2 Frame

The frame of the press is made out of two UNP 140 Steel profiles for horizontal support. The vertical support is provided by two rectangular 40 mm × 80 mm profiles with a thickness of 6.3 mm. In the middle of the U-beams, there is a 10 mm thick steel plate for the mounting of the hydraulic jack. This plate just gets welded onto the bottom of the beams. Alternatively, screw connections are certainly possible but were not explored. The U-beams are then connected with two M20 screws to the vertical beams. The entire assembly and the basket are displayed in fig. 3.3. I decided on two screws as this way the top beam acts as they have a pinned support on either end. Thus the bolts only support a vertical force. Detailed calculations underlying the choices described above can be found in app. A.2.1.

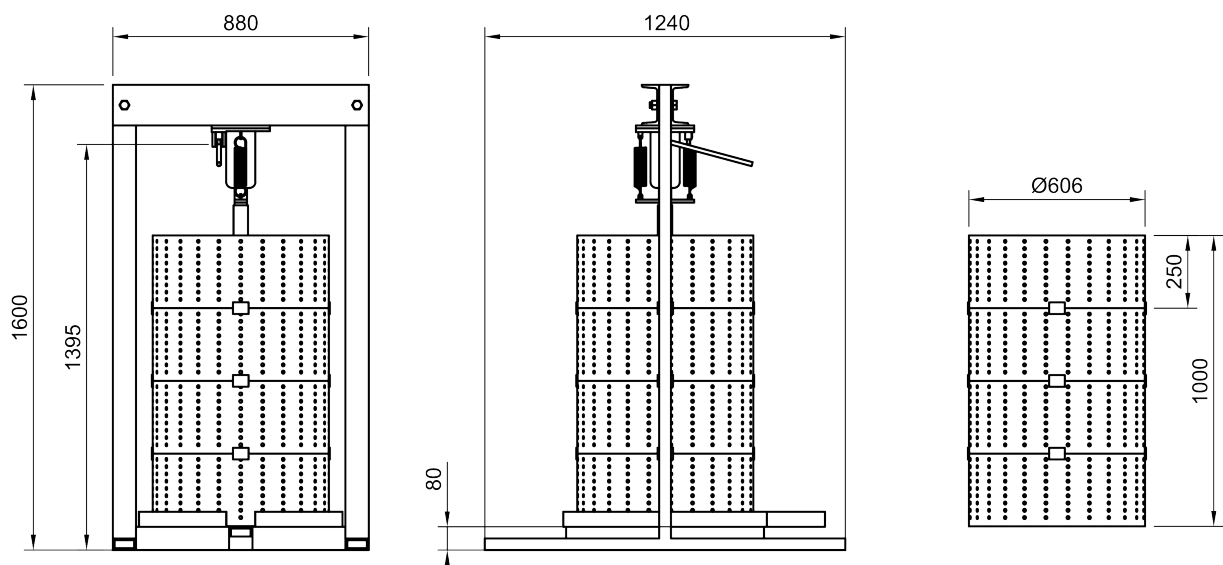

Figure 3.3. Drawings of design 1. All numbers are in mm.

3.2.3 Basket

As the diameter and height of the basket were determined by the pressure mechanism the height of the basket also got locked in. To facilitate easier access to the filtration bag at the end of the dewatering process, the basket is divided into four equal segments, each measuring 250 mm in height. Constructed from 3 mm thick sheet metal, these segments are formed into cylinders. At the bottom of the three sections is a "lip" that ensures the baskets are securely stacked on top of each other. The holes on the side do not have a filtering purpose as this task will be taken on by the filtration bag. Their only function is to allow drainage of the outflowing liquid while pressing. The density of the holes is not specified.

Ideally, the holes in the basket will be laser-cut or stamped in order to reduce manufacturing time and cost, however, if the workshops do not have this technology the holes need to be drilled by hand which is a time-consuming and tedious process. Buying off-the-shelf perforated sheet metal could be a remedy for this problem and this option should be explored with local suppliers.

The topic of using stainless steel metal sheets for the basket was mentioned in sec. 2.4.3. If stainless steel can't be obtained the same steel as in the frame can be used. However, a significant decrease in lifetime can be expected due to corrosion.

3.2.4 Conclusions for design 1

A significant upside of this design is the small amount of different parts, which are required. With one type of C-Beam, one type of rectangular beam, two pairs of nuts and bolts, and a steel plate. The entire frame of the press can be assembled. The basket and the collector can then be made out of the same 3 mm sheet metal.

With the collector being close to the ground the diversion of the drained liquid is more of a challenge. The same goes for the removal of the sludge cake. The sludge cake after dewatering has a weight of 86 kg which makes it too heavy to lift by hand. Instead of directly transferring it from the collector to a storage container, this task likely requires the use of shoveling or other equipment for handling in between. The collector can't be put any higher as this would compromise the ergonomics of the hydraulic jack.

The press head is quite heavy at 27 kg. This might make it difficult to operate the press with one person, thus violating the constraint of operation by one person.

If the necessary modifications for the upside-down operation of the hydraulic jack can't be made the ergonomics are worse, as the lever handle is not at a constant location. These

modifications take some time but are in my opinion doable as quite a few tutorials on YouTube exist (HomeCrafter, 2021).

Additionally, the implementation of splash guards might be necessary. This was noticed during the testing of the smaller press. During dewatering some of the liquid coming through the filter was spraying out. This caused the water to land on the ground and spray on the people conducting the test.

3.3 Design 2

The working of the press did not fundamentally change in the second design. The most significant changes are the orientation of the press, the exploration of external filters, and an alternative pressure mechanism in the form of a spindle such as in fig. 3.4.

3.3.1 Design changes

While the fundamental operational concept remained consistent with the horizontal design, certain constraints, such as the basket's height, were relaxed. Consequently, the diameter of the press head changed to 0.5 m and thus the basket is now 1.4 m in length. This diameter reduction also has the added benefit of an increase in pressure, which is now 6 bar instead of the previous 4.16 bar. This adjustment is expected to yield an increase in the total solid content after the dewatering process (Novak, 2006).

3.3.2 Pressure Mechanism

The travel of the car-jack is restricted, therefore stacking pieces are once again needed to press the plate to the end of the barrel. Since the basket length is much longer the spindle was designed as an alternative to shorten the process time. The detailed calculations are in app. A.3. The end of the spindle is supported by an axial bearing to ensure that the press head does not turn with the spindle. To achieve the same 12 t force, a torque of 600 Nm is required. This is a considerable amount of torque for one single individual, hence a tradeoff in performance.

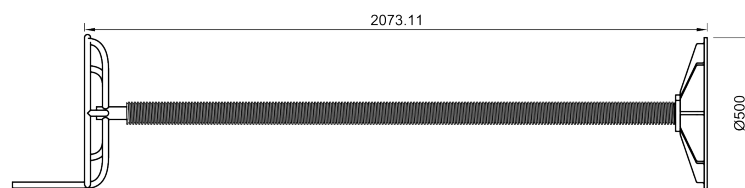

Figure 3.4. Spindle of design 2 with press head

The hydraulic jack is preferably connected with screws to the C-Beam, the exact design of the mounting needs to be adapted to the hydraulic jack used. Since the hydraulic jack is now horizontal it's crucial that the handle of the jack is facing the ground.

3.3.3 Frame

Due to the now horizontal layout of the press, the frame geometry underwent significant changes. The frame is now split into two sections that are connected with two rods. Both sections are made out of C-beams. In the C-beam where the hydraulic jack is located, additional stiffening is provided by welding steel plates to the beam.

Both the spindle and hydraulic jack versions utilize two 2000 mm long, 36 mm diameter rods to link their sections. In addition, they also bear the basket's weight. Each rod terminates with an M36 male thread, inserted through the respective holes on either section and fastened with a nut on the opposite side. The entire assembly of both versions is displayed in fig. 3.5.

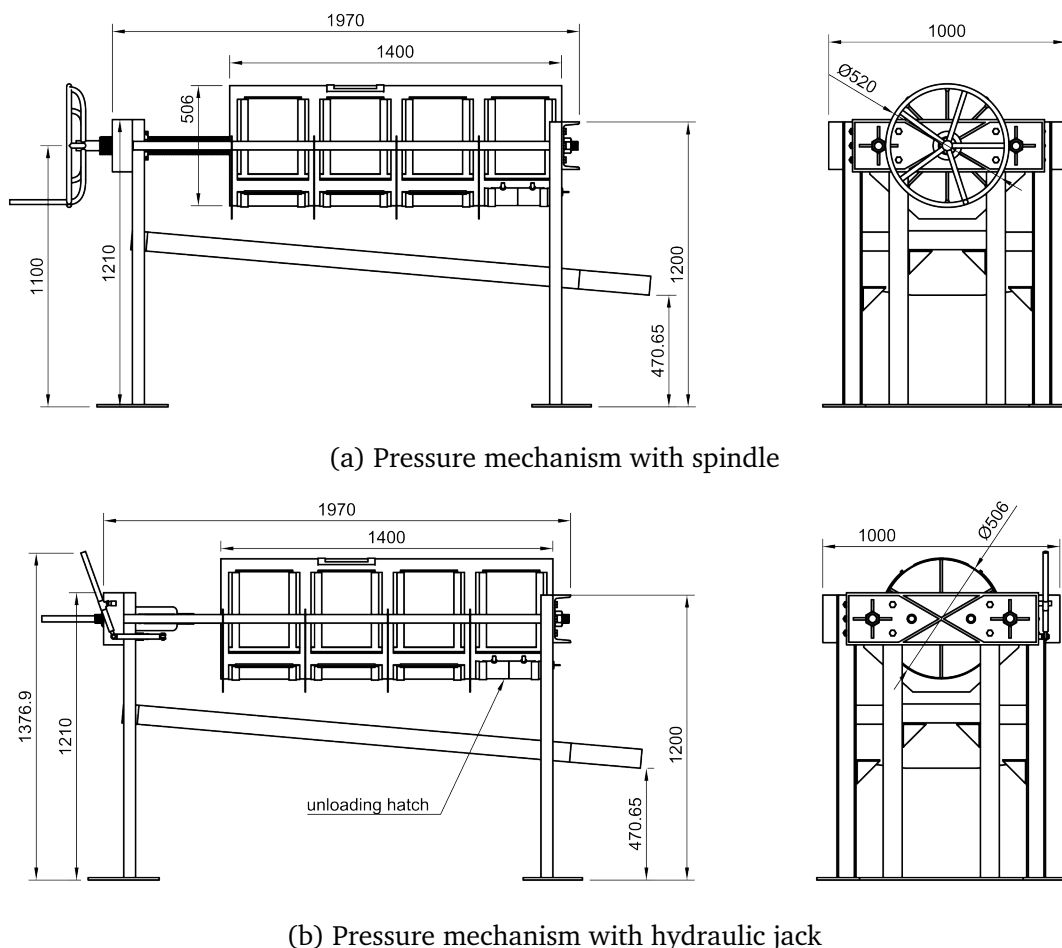

Figure 3.5. Design 2 with the different pressure mechanisms. Both the spindle and support rods of the hydraulic jack are fully inserted. All numbers are in mm.

Between the legs of the press, a collector is mounted with L-brackets. These are mounted with welding, alternatively, screw connections work as well. The collector is mounted at an angle so that all of the drained water can flow straight into a storage tank. After dewatering the collector also serves the purpose of catching the filtration bag with the sludge cake. Subsequently, the bag and the sludge cake can be conveniently pushed into, for example, a wheelbarrow for transportation away from the press. This process allows the press to be promptly prepared for another batch, while the sludge cake is unloaded from the filtration bag.

Located on the side of the C-Beam in the hydraulic design are levers designed to improve the operation of the hydraulic jack for increased comfort. These levers were incorporated based on feedback from the initial design. Positioned at 1370 mm, approximately chest height, these levers facilitate easier operation.

3.3.4 Basket

The basket is now out of one continuous piece, featuring drain holes in the lower 3/4. The basket operates with a filtration bag just like the previous design. At the basket's underside, positioned at the end, an unloading hatch (marked in fig. 3.5b) is present for easy removal of the dewatered sludge cake. Its top features a square opening used for filling both the filtration bag and the basket, sealed with rubber and secured by latches to prevent leaks.

3.3.5 Filters

As a substitute for the filtration bag, the implementation of external filters was explored with the idea of simplifying the handling of the sludge cake after dewatering. This would mainly be achieved by eliminating the step of removing the fecal sludge from the filtration bags.

The filters would be made out of a plastic or metal frame that is flexible enough to bend around the outside of the basket. Inside this frame is either a metal or fabric filter cloth. The filters slide into a bracket that is directly attached to the outside of the basket. These filters get removed and cleaned after each dewatering procedure. Alternatively, multiple sets of filters exist so that after each round of dewatering they get collected and all of them get cleaned at once at the end of the day. Ideally, these filters get cleaned with pressurized water.

3.3.6 Conclusions for design 2

The decrease in diameter in the second design is expected to yield a drier sludge cake compared to the first design, consequently resulting in a lighter sludge cake. The raised collector

improves the redirection of the drained liquid into a suitable storage container. Likewise, handling the sludge cake becomes easier, specifically the unloading of the bag from the collector.

The most apparent drawback of the design lies in the significant increase in mass, consequently raising material costs. Furthermore, the assembly's complexity increases, leading to a rise in labor hours, both of which are expected to substantially increase the overall pricing.

With the increased length of the basket, the press head has a longer distance to travel before reaching the end. Therefore more repetitions of extending and retracting of the hydraulic jack are necessary, which prolongs the dewatering process. This drawback can be mitigated by manually pushing the press head down the basket using support rods. Only after this option is used does the operation of the hydraulic jack start.

As mentioned in sec. 3.3.2 the spindle offers a faster process than the hydraulic jack. However, this comes at the cost of the dryness of the sludge cake, as it is not reasonable to expect that a single person is able to apply a torque of 600 Nm and thus generate the same 6 bar of pressure.

The major shortcoming in the implementation of filters is the requirement of tight tolerances between the press head and the basket. The gap between them needs to be watertight; otherwise, the fecal sludge exits through the gaps and not the filters. Adding a rubber seal to the outside of the press plate is a logical step to ensure water tightness. However, a seal can only do so much if tight tolerances cannot be manufactured. This raises the question of whether the associated additional costs of tighter tolerances are worth the yet unknown benefit of filters. Especially because the filtration bag does not have such issues as it functions even with a significant gap between the press plate and the basket.

The behavior of fecal sludge in the horizontal press is not clear. Due to gravity, the sludge settles at the underside of the basket. In the design process, it was assumed that the sludge would shift upwards as horizontal space gets tighter, leading to even distribution. This even distribution of sludge also ensures an even distribution of force on the press plate. If this scenario does not occur, the sludge will remain at the bottom during the compression phase, creating uneven forces that neither the support of the hydraulic press nor the spindle is designed to handle.

3.4 Discussion

Table 3.1. Quantitative comparison of Design 1 and Design 2. * = low, ** = medium, *** = high.

	Vertical Press	Horizontal Press
Weight	200 kg	380 kg - 405 kg
Cost	***	*
Material availability	***	**
Material requirements	***	**
Robustness	***	**
Capacity	**	***
System integration	**	***
System operation	**	**

In table 3.1 the press designs get quantitatively compared. The asterisks are an indicator of how well the press is expected to perform in this category.

The weight of the designs directly translates into material cost. Thus half of the mass roughly translates into half of the material cost. Contrary to the vertical press the horizontal press also requires additional construction steps. Some of them are: Stiffening for C-beam, threading of spindle, and installing hatches on the basket. Each of these steps contributes to additional costs.

Due to the requirement for more unique parts, the horizontal press performs worse in terms of material availability and requirements. This directly affects its robustness as well. Especially the spindle of the horizontal design requires more maintenance and care. For instance, the spindle requires greasing for optimal performance and since the spindle is exposed to water and isn't made of stainless steel, corrosion becomes a problem. In contrast, this is not an issue with the hydraulic car jack; at most, the oil might need occasional changing.

Regarding capacity, both designs are anticipated to perform well. The amount of fecal sludge that passes through the basket before mechanical dewatering is required depends on the solid content of the fecal sludge. Due to the larger surface area of the horizontal press, it is expected that more fecal sludge can pass through before needing dewatering compared to the vertical design. Additionally, the horizontal press can attain higher total solids after the dewatering process.

The term 'system integration' refers to how easily the press can be connected to a flocculation tank and how well the resulting sludge cake and drained liquid part can be used. In this aspect, the second design is expected to outperform the first, mainly due to its taller collector. This additional height simplifies the redirection of the drained liquid into a suitable storage

container. The same goes for the handling of the sludge cake, cumbersome shoveling is not required anymore as gravity now works for us. However, this advantage also comes at a cost of space, as this design takes up roughly double the footprint, which is something to consider if space is tight.

In theory, filters should allow for an easier operation of the horizontal design as the entire filtration bag would be replaced by easy-to-use filters on the outside of the basket. If external filters would allow for better dewatering was not explored. But for the filters to function well, a watertight seal between the press plate and basket is required. This and the additional manufacturing effort for the filters and their brackets do not indicate that filters are a suitable and cost-effective alternative to filtration bags in this application.

4 CONCLUSION

Two designs of dewatering mechanisms were studied. Their conceptual designs were developed following the material stress calculations. The designs are based on cheap structural steel, widely available in urban sub-Saharan Africa.

The primary advantages of the horizontal press (design 1) stem from its simpler design, resulting in reduced costs due to less material usage and decreased assembly time. Even if modifications to the hydraulic jack are not feasible, the design remains operational. An additional benefit lies in the commercial availability of similar presses employed in the food industry, which allows for testing on smaller scales. These benefits outweigh the drawbacks of the cumbersome handling of the sludge cake after dewatering, where it has to be moved with shovels out of the filtration bag instead of dumping it directly into a storage container.

The horizontal design (design 2) offers the benefit of improved dewatering thanks to exerting higher pressure on the sludge. Also, the height of the collector allows for simpler handling of the sludge cake after dewatering. This benefit comes with the drawback of greatly increased material and manufacturing costs due to the more complicated assembly. A challenge encountered in the horizontal design may be the fecal sludge accumulation in the lower part of the press. This behavior would introduce off-center forces on the press head which the system is not designed for.

Concerning filters. I suggest discarding this idea as the concept with the filter bag works well enough and requires less manufacturing effort.

With this in mind, my recommended design for a manually operated dewatering press would be design 1. If possible this system should be upgraded with a proper hydraulic cylinder and system to improve the ergonomics and handling. Which would then eliminate some of the bigger drawbacks.

If a horizontal concept is desired I would suggest moving away from this method of dewatering and exploring the possibility of using a filter press. However, it requires an electric water pump to operate but has the advantage that it requires less active working time.

BIBLIOGRAPHY

- Albertson, O. *et al.* (1987). “DESIGN MANUAL: DEWATERING MUNICIPAL WASTEWATER SLUDGES EPA/625/1-87/014 (NTIS PB95186417)”. In.
- Gastadello, Giada (Sept. 2021). *The agile product development process & methodology explained*. <https://maze.co/collections/product-development/agile/> [cited: 14.11.2023]. URL: <https://maze.co/collections/product-development/agile/>.
- HomeCrafter, The (Sept. 2021). *flipping the hydraulic bottle jack*. YouTube [cited: 7.10.2023]. URL: <https://www.youtube.com/watch?v=BJDM0z408sY>.
- Novak, John T. (2006). “Dewatering of Sewage Sludge”. In: *Drying Technology* 24.10, pp. 1257–1262. DOI: 10.1080/07373930600840419. eprint: <https://doi.org/10.1080/07373930600840419>. URL: <https://doi.org/10.1080/07373930600840419>.
- Peal, Andy *et al.* (May 2014). “Fecal sludge management (FSM): analytical tools for assessing FSM in cities”. In: *Journal of Water, Sanitation and Hygiene for Development* 4.3, pp. 371–383. ISSN: 2043-9083. DOI: 10.2166/washdev.2014.139. eprint: <https://iwaponline.com/washdev/article-pdf/4/3/371/384956/371.pdf>. URL: <https://doi.org/10.2166/washdev.2014.139>.
- Strande, Linda, Mariska Ronteltap, and Damir Brdjanovic (July 2014). *Faecal Sludge Management: Systems Approach for Implementation and Operation*. IWA Publishing. ISBN: 9781780404738. DOI: 10.2166/9781780404738. eprint: <https://iwaponline.com/book-pdf/906934/wio9781780404738.pdf>. URL: <https://doi.org/10.2166/9781780404738>.
- Velkushanova, Konstantina *et al.* (Apr. 2021). *Methods for Faecal Sludge Analysis*. ISBN: 9781780409115. DOI: 10.2166/9781780409122.
- William, Andruga (Oct. 2023). *Zoom call*.
- Wittel, H., C. Spura, and D. Jannasch (2021). *Roloff/Matek Maschinenelemente: Normung, Berechnung, Gestaltung*. Springer Fachmedien Wiesbaden. ISBN: 9783658341596. URL: <https://books.google.ch/books?id=nqlmzgEACAAJ>.

APPENDIX A - CALCULATIONS

A.1 Fecal Sludge accumulation

The assumptions made for the calculations were a total solids content of the untreated fecal sludge of 3.5 %. Furthermore, a capture rate of 90 % of the solids in the fecal sludge was assumed. The assumption for the dewatered sludge cake was a 20 % total solids content. $m_1 = 3835.6$ kg represents the total mass of the fecal sludge before dewatering. m_2 is the total mass of the sludge cake after dewatering all 3835.6 L of fecal sludge. m_s is the mass of only the solids in the sludge cake.

$$m_s = m_1 \cdot 0.035 \cdot 0.9 = 120.8 \text{ kg} \quad (\text{A.1})$$

$$m_2 = 120.8 \cdot \frac{1}{0.2} = 604.1 \text{ kg} \quad (\text{A.2})$$

A.2 Screw connections

This section of the appendix contains the calculations for the verification of the screw connections.

A.2.1 Vertical press

With the assumption of a beam with pinned support on either end, the acting forces on the supports are determined with a simple force and moment balance.

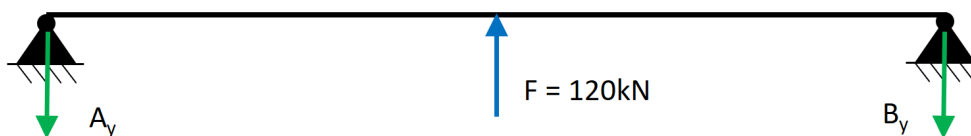

Figure A.1. Top beam of vertical press simplified to beam with pinned ends.

$$F_y 0 = F - A_y - B_y \quad (\text{A.3})$$

$$M_a 0 = -F \cdot \frac{l}{2} + B_y \cdot l \quad (\text{A.4})$$

This gives us

$$A_y = 60 \text{ kN} \quad B_y = 60 \text{ kN}$$

Each end of the top beam has two holes. Therefore each hole is subjected to $F_{vEd} = 30 \text{ kN}$.

Checking against shearing of the M20 grade 8.8 screw:

$$F_{vRd} = \beta \cdot \alpha_v \cdot A_s \cdot \frac{R_{mS}}{\gamma_{M2}} \geq F_{vEd} \quad (\text{A.5})$$

Checking bearing pressure:

$$F_{bRd} = k_1 \cdot \alpha_b \cdot d \cdot t \cdot \frac{R_m}{\gamma_{M2}} \geq F_{vEd} \quad (\text{A.6})$$

With:

$$\begin{array}{lll} \beta = 1.0 & \alpha_v = 0.5 & A_s = 245 \text{ mm}^2 \\ \gamma_{M2} = 1.25 & R_{mS} = 800 \frac{\text{N}}{\text{mm}^2} & R_m = 360 \frac{\text{N}}{\text{mm}^2} \\ k_1 = 2.5 & \alpha_b = 0.952 & d = 21 \text{ mm} \\ t_1 = 6.3 \text{ mm} & t_2 = 7 \text{ mm} & \end{array}$$

Plugging the numbers in:

$$F_{vRd} = 78.4 \text{ kN} \quad (\text{A.7})$$

$$F_{bRd} = 90.7 \text{ kN} \quad (\text{A.8})$$

Both of them are greater than 30 kN so the connections suffice.

A.2.2 Horizontal Press

With the horizontal press, the screws at the end of the rods are primarily subjected to a tension force. The integrity of these connections is checked with the following equation. The ends of the rods are M36 threads. Each thread is subjected to $F_{tEd} = 60 \text{ kN}$.

$$F_{tRd} = k_2 \cdot A_s \cdot \frac{R_{mS}}{\gamma_{M2}} \geq F_{tEd} \quad (\text{A.9})$$

With:

$$\begin{aligned} k_2 &= 0.9 & A_s &= 817 \text{ mm}^2 \\ R_{mS} &= 360 \frac{\text{N}}{\text{mm}^2} & \gamma_{M2} &= 1.25 \end{aligned}$$

This yields us:

$$F_{tRd} = 211.8 \text{ kN} \quad (\text{A.10})$$

Which greatly suffices.

A.3 Spindle

With a length of 1.6 m it must be verified that buckling does not occur.

$$d_3 = \sqrt[4]{\frac{64 \cdot F \cdot S \cdot l_k^2}{\pi^3 \cdot E}} = 60.46 \text{ mm} \quad (\text{A.11})$$

With $F = 120 \text{ kN}$, $S = 8$, $E = 210 \text{ GPa}$, $l_k = 1190 \text{ mm}$. A Trapezoidal thread is chosen as this is the usual form of thread for such an application (Wittel, Spura, and Jannasch, 2021). The next closest thread is TR75x10 with $d_3 = 64 \text{ mm}$

$$\tan \varphi = \frac{n \cdot P}{d_2 \cdot \pi} \quad (\text{A.12})$$

$$T = \frac{F}{2} \cdot [d_2 \cdot \tan(\varphi \pm \varrho') + d_L \cdot \mu_L] = 635.469 \text{ Nm} \quad (\text{A.13})$$

With $F = 120 \text{ kN}$, $d_2 = 70 \text{ mm}$, assumption of lubricated thread $\varrho' = 6$, $P = 10$ and $n = 1$. The remaining friction variables were omitted as the end of the spindle is supported by a bearing. T is the required torque to achieve the force of 120 kN.

Checking for torsional stress.

$$\tau_t = \frac{T}{W_t} \leq \tau_{t \text{ zul}} = 12.34 \frac{\text{N}}{\text{mm}^2} \quad (\text{A.14})$$

With $W_t = 51471.85 \text{ mm}^3$. τ_t is low enough without looking at $\tau_{t \text{ zul}}$

And then for compression strength

$$\sigma_{d(z)} = \frac{F}{A_3} \leq \sigma_{d(z)zul} = 37.3 \frac{\text{N}}{\text{mm}^2} \quad (\text{A.15})$$

With $A_3 = 3217 \text{ mm}^2$. The stress low enough to not warrant a check with $\sigma_{d(z)zul}$

Because of the slenderness of the spindle:

$$\lambda = \frac{4 \cdot l_k}{d_3} = 74.375 \quad (\text{A.16})$$

As $\lambda < \lambda_0$ the buckling will be inelastic.

$$\sigma_K = R_{p0,2} \left[1 - 0,2 \cdot \left(\frac{\lambda}{\lambda_0} \right)^2 \right] \quad (\text{A.17})$$

As we're using S235 $\lambda_0 = 105$

$$\sigma_K = 310 - 1,14 \cdot \lambda = 225.21 \frac{\text{N}}{\text{mm}^2} \quad (\text{A.18})$$

σ_K is the stress at which the column buckles. This stress gets checked against the compression stress $\sigma_{d(z)}$.

And at last:

$$S_{erf} \leq S = \frac{\sigma_K}{\sigma_{d(z)}} = 6.04 \quad (\text{A.19})$$

With $S_{erf} = 3$ this condition is fulfilled.

As the very last step, the "female" thread gets checked

$$p = \frac{F \cdot P}{l_1 \cdot d_2 \cdot \pi \cdot H_1} \leq p_{zul} \quad (\text{A.20})$$

With $H_1 = 5$, $p_{zul} = 10$ and $d_2 = 70 \text{ mm}$ we obtain that $l_1 = 150 \text{ mm}$ is a valid length.

A.4 Stress

The beams where the hydraulic jack is mounted are subjected to the greatest forces. Therefore they received a special focus. The stresses in these beams were calculated with the FEM-Tool of Fusion360. The forces of the hydraulic jack were always simulated using 120 kN. In this part of the appendix, a beam of design 2 is used as an example. The same procedure was applied for the other beam of designs 1.

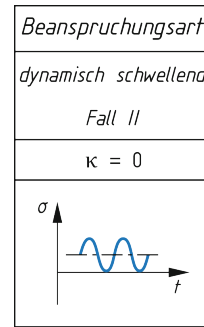
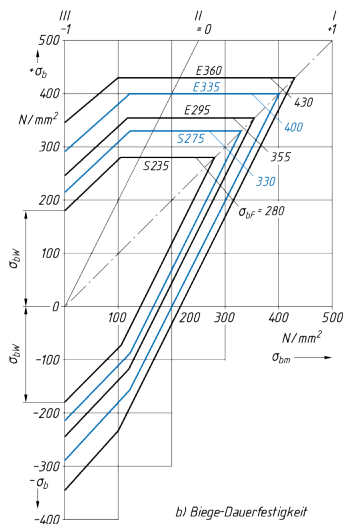

(b) Load case

(a) bending fatigue strength diagram

Figure A.2. Fatigue strength diagram with the associated load case to determine the maximum bending moment. (Source: Wittel, Spura, and Jannasch (2021))

The most significant stresses of the beams are caused by bending. Thus with the fatigue strength diagram for bending stress in fig. A.2 the maximum allowed stress where fatigue failure does not occur can be determined. With a safety of $S_z = 1.2$ and shape factor $K_t = 0.9$ the bending stress should not exceed:

$$280 \frac{\text{N}}{\text{mm}^2} \cdot \frac{1}{1.2} \cdot 0.9 = 210 \frac{\text{N}}{\text{mm}^2} \quad (\text{A.21})$$

In the case of the beam in fig. A.4, this criterion is sufficiently satisfied. This means the beam theoretically survives infinite dewatering cycles.

The other components in either design are exposed to low enough stresses ($\leq 100 \frac{\text{N}}{\text{mm}^2}$) that such validations are not required.

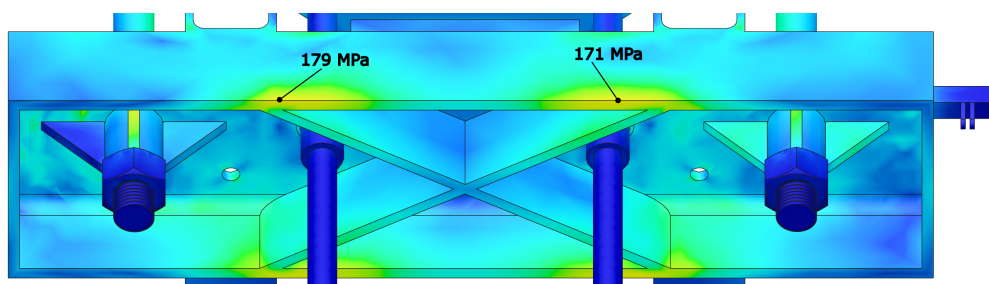

Figure A.3. FEM of Design 2

Figure A.4. FEM-analysis of a beam from design two. Highlighted are the two most significant stresses of the beam.



Declaration of originality

The signed declaration of originality is a component of every semester paper, Bachelor's thesis, Master's thesis and any other degree paper undertaken during the course of studies, including the respective electronic versions.

Lecturers may also require a declaration of originality for other written papers compiled for their courses.

I hereby confirm that I am the sole author of the written work here enclosed and that I have compiled it in my own words. Parts excepted are corrections of form and content by the supervisor.

Title of work (in block letters):

Designing a manual press for blackwater dewatering

Authored by (in block letters):

For papers written by groups the names of all authors are required.

Name(s):

Hugentobler

First name(s):

Magnus

With my signature I confirm that

- I have committed none of the forms of plagiarism described in the '[Citation etiquette](#)' information sheet.
- I have documented all methods, data and processes truthfully.
- I have not manipulated any data.
- I have mentioned all persons who were significant facilitators of the work.

I am aware that the work may be screened electronically for plagiarism.

Place, date

Dübendorf, 27.11.2023

Signature(s)

For papers written by groups the names of all authors are required. Their signatures collectively guarantee the entire content of the written paper.